

**STORMWATER MANAGEMENT REPORT**  
**Marlton Crossing**

**100 Centre Boulevard**  
Block 24.21, Lot 1  
Township of Evesham  
Burlington County  
New Jersey

**PREPARED FOR**  
**MARLTON CROSSING DEV AMS LLC**  
1 Bridge Plaza North, Suite 840  
Fort Lee, New Jersey 07024

**PREPARED BY**



***Taylor Wiseman & Taylor***  
**ENGINEERS | SURVEYORS | SCIENTISTS**

804 East Gate Dr, Suite 100  
Mount Laurel, New Jersey 08054  
Phone: 856-235-7200  
Fax: 856-722-9250

A handwritten signature in black ink, appearing to read 'Vladislav A. Koldomasov', is written over a horizontal line.

Vladislav A. Koldomasov, PE  
NJ Professional Engineer No.24GE05529600  
Certificate of Authorization No. 24GA28032900

Project No.: 07380.1000.00  
June 25th, 2025  
Revised: August 27, 2025

Assisted By: Matthew Young



**TABLE OF CONTENTS:**

I. Introduction..... 3

II. Hydrology ..... 3

    A. Methodology ..... 3

    B. Soils ..... 2

    C. Time of Concentration ..... 2

    D. Rainfall Data..... 2

III. Stormwater Conveyance Design ..... 2

IV. Stormwater Management..... 3

    A. Groundwater Recharge..... 3

    B. Runoff Quality..... 3

    C. Runoff Quantity..... 4

    D. Groundwater Mounding Analysis..... 7

V. Conclusion ..... 7

**APPENDICES:**

- A. Figures
  - Figure 1 – SSURGO Soils Map
  - Figure 2 – New Jersey Rainfall Distribution Regions
  - Figure 3 – NOAA Rainfall Depth Data
  - Figure 4 – NOAA Rainfall Intensity Data
- B. Pre-Construction Storm Routings
- C. Post-Construction Storm Routings
- D. Stormwater Conveyance Design
- E. ADS StormTech Detail
- F. Groundwater Recharge
- G. Groundwater Mounding Analysis
- H. Existing and Proposed Drainage Plans



## I. Introduction

The purpose of this report is to demonstrate compliance with New Jersey stormwater management regulations through hydrologic and hydraulic analyses. The proposed development is located at Block 24.21, Lot 1 in Evesham Township, Burlington County, New Jersey. The current lot is approximately 8.81 acres and is zoned Commercial District as well as part of the Centre Boulevard Redevelopment Plan.

The subject property currently contains multiple professional office buildings with associated drive aisles and parking. The stormwater, in its existing state, collects on site and discharges at two points of analyses. Point Of Analysis #1 (POA #1) is located to the northerly side of the property and discharges to existing drainage infrastructure adjacent to Marlton Pike. Point of Analysis #2 (POA #2) is located to the southerly side of the property and discharges to existing drainage infrastructure along Lippincott Drive. The drainage point of analyses are identified on the drainage area plan in [Appendix H](#).

The proposed development will include a mix of studio, one bedroom, two bedroom, and three-bedroom units with a total of 325 units. In addition, on-site improvements include a parking garage, sidewalks, three amenity courtyards, and drive aisles.

This project qualifies as a major development under N.J.A.C. 7:8 due to the disturbance of one acre or more of land. As such, the stormwater management design must address runoff quantity control. Per N.J.A.C. 7:8-5.6, the design demonstrates that there is no increase, as compared to the pre-construction conditions, in the peak runoff rates of stormwater leaving the site for the current and projected 2-, 10-, and 100-year storm events, and that the increased volume or change in timing of stormwater runoff will not increase flood damage at or downstream of the site. Groundwater recharge and runoff quality will not be addressed as part of this design. Groundwater recharge does not apply to projects within the “urban redevelopment area” (PA-1 metropolitan area) as well as full build out sites. The stormwater runoff quality standard under N.J.A.C. 7:8-5.5 does not apply, as the project does not include an increase in impervious surface from which runoff is generated from motor vehicle surfaces. Therefore, TSS removal is not required for this development.

## II. Hydrology

### A. Methodology

The hydrographs for this project have been generated employing “HydroCAD”, version 10.2, a stormwater hydrograph routing software based on the USDA Natural Resources Conservation Service (NRCS) TR-55 computer modeling techniques. The runoff volumes for the various cover and soil types have been calculated separately and the hydrographs combined. The Standard Unit Hydrograph with a Region C rainfall distribution was used from NOAA Atlas 14 pursuant to New Jersey Bulletin No. NJ210-12-1. Hydrographs were generated to produce peak flows for the various storms. This formed the existing base condition to compare with the computed pre-

and post-developed peak flows. Figure 2 in [Appendix A](#) shows a map of the New Jersey Rainfall Distribution Regions.

## B. Soils

The hydrologic soil characteristics of the watershed are derived from the National Resource Conservation Service Web Soil Survey ([Appendix A](#), Figure 1). The site soils are defined as Marlton (MapB) and Collington (ComB) which correspond to Hydrologic Soil Group B & C.

## C. Time of Concentration

Time of concentration was calculated from the hydraulically most distant point for the catchment areas per Chapter 3 of the USDA Natural Resources Conservation Service (NRCS) TR-55 manual. Existing and proposed drainage maps can be found in [Appendix H](#) with the calculated time of concentrations illustrated therein.

## D. Rainfall Data

The rainfall depths and intensities were obtained from NOAA’s NWS Precipitation Frequency Data Server Website. The rainfall depth data was used in modeling the hydrographs for the existing and proposed basins and is measured in inches. See [Appendix A](#) for rainfall data.

For the calculation of stormwater runoff, NOAA precipitation depths of the two-, 10-, and 100-year storm events were adjusted according to N.J.A.C. 7:8-5.7(c) and 7:8-5.7(d) with the specified adjustment factors for Camden County:

	Adjusted Precipitation Depth (in)		
	2-year	10-year	100-year
NOAA Rainfall	3.32	5.04	8.36
Adjustment Factor	0.99	1.01	1.04
<b>Current Rainfall</b>	<b>3.29</b>	<b>5.09</b>	<b>8.69</b>
Adjustment Factor	1.17	1.18	1.32
<b>Future Rainfall</b>	<b>3.88</b>	<b>5.95</b>	<b>11.04</b>

## III. Stormwater Conveyance Design

The stormwater management design has been addressed using stormwater inlets and piping. The on-site storm pipe calculations were designed using the rational method utilizing NOAA Atlas 25-year rainfall intensity. Supporting calculations are provided in [Appendix D](#) of this report.

Stormwater management for the proposed development has been addressed using one (1) small-scale subsurface infiltration basin. The small-scale basin is developed by ADS StormTech. Details of the system are provided in [Appendix E](#). The design intent of the proposed basin is to reduce the runoff quantity from on-site, retain and infiltrate the entire 100-year projected net increase volume of the pre-developed

condition of the entire site. The underground system will collect approximately 0.44 acres of roof runoff to maintain allowable discharge at POA #1.

The proposed facilities have been designed in accordance with the above referenced Stormwater Management Rules, as well as the *New Jersey Stormwater Best Management Practices Manual*, New Jersey Department of Environmental Protection, Division of Watershed Management, March 2021.

## **IV. Stormwater Management**

The project will result in more than one (1) acre of disturbance and therefore is classified as a “Major Development” subject to compliance with the July 2023 NJDEP Stormwater Management (SWM) Rules (NJAC 7.8).

As stated in the introduction, due to factors such as not increasing the motor vehicle impervious by more than a quarter acre under the jurisdiction of NJAC 7:8 and 5,000 square feet under the jurisdiction of Evesham Township Ordinance Section 62-28D.(18), stormwater quality will not be required for this development.

Stormwater Management design requirements provided in NJAC 7:8 involving groundwater recharge, stormwater quality, and stormwater quantity are provided below.

### **A. Groundwater Recharge**

The proposed project site is situated within New Jersey's Metropolitan Planning Area 1 (PA-1) zone. According to the New Jersey Department of Environmental Protection (NJDEP) stormwater management rules (N.J.A.C. 7:8), properties located in PA-1 zones are exempt from groundwater recharge requirements. This exemption is designed to facilitate urban redevelopment and support the state's planning goals for densely populated areas.

By adhering to the exemption outlined in N.J.A.C. 7:8-5.4-2, the project can proceed without the need for groundwater recharge measures, aligning with the state's objectives for sustainable urban development and efficient land use in Metropolitan Planning Area 1.

Although the development is exempt from the groundwater recharge requirement, the design does implement a small-scale subsurface infiltration basin which will retain and infiltrate the 100-year projected net increase volume to ensure the site meets the water quantity requirements. The proposed stormwater management system will provide an annual recharge volume of 56,216 cubic feet which would have exceeded the required annual recharge deficit of 4,556 cubic feet. Annual recharge calculations are provided in [Appendix F](#).

### **B. Runoff Quality**

Stormwater Quality: N.J.A.C. 7:8-5.5, *Stormwater runoff quality standards*, requires the design engineer to perform the following:

Per N.J.A.C. 7:8-5.5.a, *This section contains the minimum design and performance standards to control stormwater runoff quality impacts of major development. Stormwater runoff quality standards are applicable when the major development results in an increase of one-quarter acre or more of regulated motor vehicle surface.*

*Furthermore, per Evesham Township Ordinance Section 62-28D.(18) stormwater runoff quality standards are applicable when the major development results in an increase of 5,000 square feet of regulated motor vehicle surface.*

The proposed development will not increase motor vehicle impervious surfaces. The existing site has 3.30 ± acres of motor vehicle surface. This is greater than the 2.50 ± acres of motor vehicle surface under proposed conditions. Therefore, stormwater runoff quality standards do not apply.

### C. Runoff Quantity

Stormwater Quantity: N.J.A.C. 7:8-5.6, *Stormwater runoff quantity standards, requires the design engineer to perform the following:*

*Per N.J.A.C. 7:8-5.6.b.2, Demonstrate through hydrologic and hydraulic analysis that there is no increase, as compared to the pre-construction condition, in the peak runoff rates of stormwater leaving the site for the current and projected two-, 10-, and 100-year storm events, as defined and determined pursuant to N.J.A.C. 7:8-5.7(c) and (d), respectively, and that the increased volume or change in timing of stormwater runoff will not increase flood damage at or downstream of the site. This analysis shall include the analysis of impacts of existing land uses and projected land uses assuming full development under existing zoning and land use ordinances in the drainage area;*

**Table 1: Hydrologic Parameters for Pre-developed Model**

Drainage Area	Location	Area (Ac)	Cover Condition	Soil Group	Runoff Coeff.	Time of Concentration (min)	
						Current	Future
E-1	POA #1	5.19	Impervious	-	98	4.4	4.3
		2.0	Open Space	B	61	12.2	11.4
		1.29	Open Space	C	74		
E-2	POA #2	0.42	Impervious	-	98	2.7	2.6
		0.22	Open Space	B	61	2.7	2.5

Using the hydrologic parameters in the table above, the results from the drainage areas modeled in *HydroCAD* and can be found in [Appendix B](#).

A summary of the calculated total pre-developed peak flows for each of the modeled drainage areas are shown in Table 2 below:

**Table 2: Total Pre-Developed Peak Flows (cfs)**

Storm Event	Drainage Area to Offsite 1					
	2-Year (Current) cfs	2-Year (Future) cfs	10-Year (Current) cfs	10-Year (Future) cfs	100-Year (Current) cfs	100-Year (Future) cfs
Area E1	16.49	20.24	27.32	33.16	50.44	66.96
Area E2	1.55	1.91	2.64	3.22	5.00	6.66

The total pre-developed peak flows shown above were calculated to determine the allowable post-developed peak flows for the 2, 10, & 100-year storm events.

There are two (2) overall Points of Analyses on the site as detailed in the “Proposed Drainage Area Plan” located in [Appendix H](#).

The hydrologic parameters for post-development conditions are tabulated below:

**Table 3: Hydrologic Parameters for Pre-developed Model**

Drainage Area	Location	Area (Ac)	Cover Condition	Soil Group	Runoff Coeff.	Time of Concentration (min)	
						Current	Future
P-1A	POA #1	0.44	Impervious	-	98	5	5
P-1B	POA #1	5.07	Impervious	-	98	4.4	4.3
		1.85	Open Space	B	61	12.2	11.4
		1.2	Open Space	C	74		
P-2	POA #2	0.28	Impervious	-	98	2.7	2.6
		0.26	Open Space	B	61	2.7	2.5

A summary of the calculated total Post-developed peak flows for each of the modeled drainage areas are shown in Tables 4 & 5 below:

**Table 4: Total Post-Developed Peak Flows For Point of Analysis #1 (cfs)**

Storm Event	Drainage Area to POA #1					
	2-Year (Current) cfs	2-Year (Future) cfs	10-Year (Current) cfs	10-Year (Future) cfs	100-Year (Current) cfs	100-Year (Future) cfs
E-1 Existing Conditions <b>Allowable</b>	<b>16.49</b>	<b>20.24</b>	<b>27.32</b>	<b>33.16</b>	<b>50.44</b>	<b>66.96</b>
P-1 Post Development <b>Peak Flow</b>	<b>16.09</b>	<b>19.72</b>	<b>26.57</b>	<b>32.21</b>	<b>48.91</b>	<b>65.78</b>

The peak flow rates in Table 4 demonstrate the runoff rates are not increased to Point of Analysis #1 under post development conditions.

**Table 5: Total Post-Developed Peak Flows For Point of Analysis #2 (cfs)**

Storm Event	Drainage Area to POA #2					
	2-Year (Current) cfs	2-Year (Future) cfs	10-Year (Current) cfs	10-Year (Future) cfs	100-Year (Current) cfs	100-Year (Future) cfs
E-2 Existing Conditions <b>Allowable</b>	<b>1.55</b>	<b>1.91</b>	<b>2.64</b>	<b>3.22</b>	<b>5.00</b>	<b>6.66</b>
P-2 Post Development <b>Peak Flow</b>	<b>1.09</b>	<b>1.38</b>	<b>1.97</b>	<b>2.45</b>	<b>3.95</b>	<b>5.37</b>

The peak flow rates in Table 5 demonstrate the runoff rates are not increased to Point of Analysis #2 under post development conditions.

Furthermore, the total net increase of volume generated by the largest 100-year projected storm between the two points of analyses is 0.066 acre-feet or 2,875 cubic feet. The proposed small-scale subsurface basin is designed to retain and infiltrate a total of 0.114 acre-feet or 4,965 cubic feet below the first orifice.

Therefore, runoff quantity standards are met demonstrating that the design does not increase peak runoff rates for the current and projected 2-, 10-, and 100-year storm events, as well as infiltrating the entire net increase volume of the pre-developed conditions.

## D. Groundwater Mounding Analysis

A groundwater mounding analysis was performed for the proposed basin using the Hantush Method Spreadsheet developed by the U.S.G.S. and published in “Scientific Investigations Report #2010-5102-Simulations of Groundwater Mounding Beneath Hypothetical Stormwater Infiltration Basins,” U.S. Department of Environmental Protection. The analysis utilizes an infiltration depth equal to the height of the first outlet control above the bottom of the basin and includes the following data:

	<b>Small-Scale Subsurface Infiltration Basin #1</b>
<b>Recharge (infiltration) rate (R)</b>	0.5 in/hr
<b>Specific yield (medium sand) (S<sub>y</sub>)</b>	15% = 0.15
<b>Horizontal hydraulic conductivity (K<sub>h</sub>)</b>	2.50 in/hr
<b>Approximate ½ basin bottom dimensions</b>	X=44.53', Y=19.75'
<b>Duration of infiltration period (t)</b>	33.87 hrs
<b>Initial thickness of saturation zone (h<sub>i</sub>(0))</b>	10.00 feet

Below are results of the groundwater mounding analysis:

	<b>Small-Scale Subsurface Infiltration Basin #1</b>
<b>Max. mounding height beneath center of basin at end of infiltration period (ft.)</b>	5.58
<b>Mounding height at perimeter of basin (x direction) (ft.)</b>	3.00
<b>Mounding height at perimeter of basin (y direction) (ft.)</b>	3.91
<b>Seasonal high water table elevation (ft.)</b>	81.0*
<b>Maximum mounding elevation beneath center of basin (ft.)</b>	86.58
<b>Proposed basin bottom elevation (ft.)</b>	90.00
<b>Maximum mounding elevation at perimeter of basin (ft.)</b>	84.91
<b>Proposed basin bottom elevation at perimeter of basin (ft.)</b>	90.00

\*SHWT not encountered; elevation used at the bottom of the test pit.

Based on the above results and the assumed seasonal high-water table elevation of the basin, it suggests that impacts of groundwater mounding associated with the presence of the basin should not extend above the bottom of the basin.

Refer to [Appendix G](#) for the results of the groundwater mounding analysis performed using the Hantush Method Spreadsheet.

## V. Conclusion

The information provided within this report demonstrates that the stormwater management requirements for a major development in N.J.A.C. 7:8 have been met.



**APPENDIX A: FIGURES**



**FIGURE 1 – SSURGO SOILS MAP**





United States  
Department of  
Agriculture

**NRCS**

Natural  
Resources  
Conservation  
Service

A product of the National  
Cooperative Soil Survey,  
a joint effort of the United  
States Department of  
Agriculture and other  
Federal agencies, State  
agencies including the  
Agricultural Experiment  
Stations, and local  
participants

# Custom Soil Resource Report for **Burlington County, New Jersey**



# Preface

---

Soil surveys contain information that affects land use planning in survey areas. They highlight soil limitations that affect various land uses and provide information about the properties of the soils in the survey areas. Soil surveys are designed for many different users, including farmers, ranchers, foresters, agronomists, urban planners, community officials, engineers, developers, builders, and home buyers. Also, conservationists, teachers, students, and specialists in recreation, waste disposal, and pollution control can use the surveys to help them understand, protect, or enhance the environment.

Various land use regulations of Federal, State, and local governments may impose special restrictions on land use or land treatment. Soil surveys identify soil properties that are used in making various land use or land treatment decisions. The information is intended to help the land users identify and reduce the effects of soil limitations on various land uses. The landowner or user is responsible for identifying and complying with existing laws and regulations.

Although soil survey information can be used for general farm, local, and wider area planning, onsite investigation is needed to supplement this information in some cases. Examples include soil quality assessments (<http://www.nrcs.usda.gov/wps/portal/nrcs/main/soils/health/>) and certain conservation and engineering applications. For more detailed information, contact your local USDA Service Center (<https://offices.sc.egov.usda.gov/locator/app?agency=nrcs>) or your NRCS State Soil Scientist ([http://www.nrcs.usda.gov/wps/portal/nrcs/detail/soils/contactus/?cid=nrcs142p2\\_053951](http://www.nrcs.usda.gov/wps/portal/nrcs/detail/soils/contactus/?cid=nrcs142p2_053951)).

Great differences in soil properties can occur within short distances. Some soils are seasonally wet or subject to flooding. Some are too unstable to be used as a foundation for buildings or roads. Clayey or wet soils are poorly suited to use as septic tank absorption fields. A high water table makes a soil poorly suited to basements or underground installations.

The National Cooperative Soil Survey is a joint effort of the United States Department of Agriculture and other Federal agencies, State agencies including the Agricultural Experiment Stations, and local agencies. The Natural Resources Conservation Service (NRCS) has leadership for the Federal part of the National Cooperative Soil Survey.

Information about soils is updated periodically. Updated information is available through the NRCS Web Soil Survey, the site for official soil survey information.

The U.S. Department of Agriculture (USDA) prohibits discrimination in all its programs and activities on the basis of race, color, national origin, age, disability, and where applicable, sex, marital status, familial status, parental status, religion, sexual orientation, genetic information, political beliefs, reprisal, or because all or a part of an individual's income is derived from any public assistance program. (Not all prohibited bases apply to all programs.) Persons with disabilities who require

alternative means for communication of program information (Braille, large print, audiotape, etc.) should contact USDA's TARGET Center at (202) 720-2600 (voice and TDD). To file a complaint of discrimination, write to USDA, Director, Office of Civil Rights, 1400 Independence Avenue, S.W., Washington, D.C. 20250-9410 or call (800) 795-3272 (voice) or (202) 720-6382 (TDD). USDA is an equal opportunity provider and employer.

# Contents

---

<b>Preface</b> .....	2
<b>How Soil Surveys Are Made</b> .....	5
<b>Soil Map</b> .....	8
Soil Map.....	9
Legend.....	10
Map Unit Legend.....	11
Map Unit Descriptions.....	11
Burlington County, New Jersey.....	13
AdmkB—Adelphia fine sandy loam, clayey substratum, 2 to 5 percent slopes.....	13
ComB—Collington fine sandy loam, 2 to 5 percent slopes.....	14
MapB—Marlton fine sandy loam, 2 to 5 percent slopes.....	16
<b>References</b> .....	18

# How Soil Surveys Are Made

---

Soil surveys are made to provide information about the soils and miscellaneous areas in a specific area. They include a description of the soils and miscellaneous areas and their location on the landscape and tables that show soil properties and limitations affecting various uses. Soil scientists observed the steepness, length, and shape of the slopes; the general pattern of drainage; the kinds of crops and native plants; and the kinds of bedrock. They observed and described many soil profiles. A soil profile is the sequence of natural layers, or horizons, in a soil. The profile extends from the surface down into the unconsolidated material in which the soil formed or from the surface down to bedrock. The unconsolidated material is devoid of roots and other living organisms and has not been changed by other biological activity.

Currently, soils are mapped according to the boundaries of major land resource areas (MLRAs). MLRAs are geographically associated land resource units that share common characteristics related to physiography, geology, climate, water resources, soils, biological resources, and land uses (USDA, 2006). Soil survey areas typically consist of parts of one or more MLRA.

The soils and miscellaneous areas in a survey area occur in an orderly pattern that is related to the geology, landforms, relief, climate, and natural vegetation of the area. Each kind of soil and miscellaneous area is associated with a particular kind of landform or with a segment of the landform. By observing the soils and miscellaneous areas in the survey area and relating their position to specific segments of the landform, a soil scientist develops a concept, or model, of how they were formed. Thus, during mapping, this model enables the soil scientist to predict with a considerable degree of accuracy the kind of soil or miscellaneous area at a specific location on the landscape.

Commonly, individual soils on the landscape merge into one another as their characteristics gradually change. To construct an accurate soil map, however, soil scientists must determine the boundaries between the soils. They can observe only a limited number of soil profiles. Nevertheless, these observations, supplemented by an understanding of the soil-vegetation-landscape relationship, are sufficient to verify predictions of the kinds of soil in an area and to determine the boundaries.

Soil scientists recorded the characteristics of the soil profiles that they studied. They noted soil color, texture, size and shape of soil aggregates, kind and amount of rock fragments, distribution of plant roots, reaction, and other features that enable them to identify soils. After describing the soils in the survey area and determining their properties, the soil scientists assigned the soils to taxonomic classes (units). Taxonomic classes are concepts. Each taxonomic class has a set of soil characteristics with precisely defined limits. The classes are used as a basis for comparison to classify soils systematically. Soil taxonomy, the system of taxonomic classification used in the United States, is based mainly on the kind and character of soil properties and the arrangement of horizons within the profile. After the soil

## Custom Soil Resource Report

scientists classified and named the soils in the survey area, they compared the individual soils with similar soils in the same taxonomic class in other areas so that they could confirm data and assemble additional data based on experience and research.

The objective of soil mapping is not to delineate pure map unit components; the objective is to separate the landscape into landforms or landform segments that have similar use and management requirements. Each map unit is defined by a unique combination of soil components and/or miscellaneous areas in predictable proportions. Some components may be highly contrasting to the other components of the map unit. The presence of minor components in a map unit in no way diminishes the usefulness or accuracy of the data. The delineation of such landforms and landform segments on the map provides sufficient information for the development of resource plans. If intensive use of small areas is planned, onsite investigation is needed to define and locate the soils and miscellaneous areas.

Soil scientists make many field observations in the process of producing a soil map. The frequency of observation is dependent upon several factors, including scale of mapping, intensity of mapping, design of map units, complexity of the landscape, and experience of the soil scientist. Observations are made to test and refine the soil-landscape model and predictions and to verify the classification of the soils at specific locations. Once the soil-landscape model is refined, a significantly smaller number of measurements of individual soil properties are made and recorded. These measurements may include field measurements, such as those for color, depth to bedrock, and texture, and laboratory measurements, such as those for content of sand, silt, clay, salt, and other components. Properties of each soil typically vary from one point to another across the landscape.

Observations for map unit components are aggregated to develop ranges of characteristics for the components. The aggregated values are presented. Direct measurements do not exist for every property presented for every map unit component. Values for some properties are estimated from combinations of other properties.

While a soil survey is in progress, samples of some of the soils in the area generally are collected for laboratory analyses and for engineering tests. Soil scientists interpret the data from these analyses and tests as well as the field-observed characteristics and the soil properties to determine the expected behavior of the soils under different uses. Interpretations for all of the soils are field tested through observation of the soils in different uses and under different levels of management. Some interpretations are modified to fit local conditions, and some new interpretations are developed to meet local needs. Data are assembled from other sources, such as research information, production records, and field experience of specialists. For example, data on crop yields under defined levels of management are assembled from farm records and from field or plot experiments on the same kinds of soil.

Predictions about soil behavior are based not only on soil properties but also on such variables as climate and biological activity. Soil conditions are predictable over long periods of time, but they are not predictable from year to year. For example, soil scientists can predict with a fairly high degree of accuracy that a given soil will have a high water table within certain depths in most years, but they cannot predict that a high water table will always be at a specific level in the soil on a specific date.

After soil scientists located and identified the significant natural bodies of soil in the survey area, they drew the boundaries of these bodies on aerial photographs and

## Custom Soil Resource Report

identified each as a specific map unit. Aerial photographs show trees, buildings, fields, roads, and rivers, all of which help in locating boundaries accurately.

# Soil Map

---

The soil map section includes the soil map for the defined area of interest, a list of soil map units on the map and extent of each map unit, and cartographic symbols displayed on the map. Also presented are various metadata about data used to produce the map, and a description of each soil map unit.

# Custom Soil Resource Report Soil Map

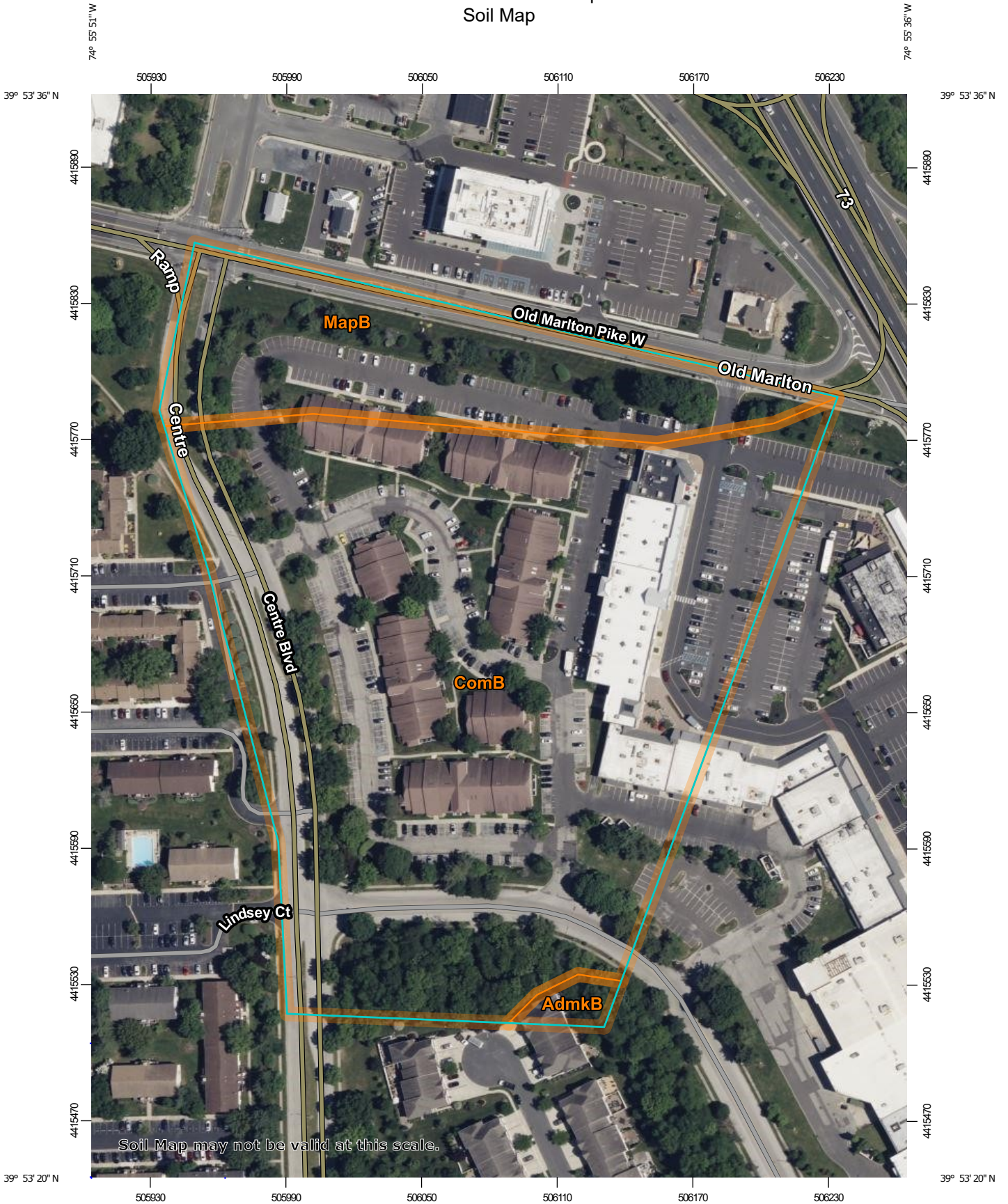



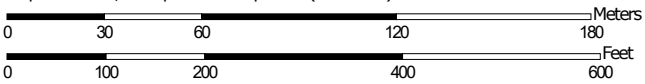











Map Scale: 1:2,330 if printed on A portrait (8.5" x 11") sheet.



Map projection: Web Mercator Corner coordinates: WGS84 Edge tics: UTM Zone 18N WGS84

## MAP LEGEND

	Area of Interest (AOI)		Spoil Area
	Area of Interest (AOI)		Stony Spot
<b>Soils</b>			Very Stony Spot
	Soil Map Unit Polygons		Wet Spot
	Soil Map Unit Lines		Other
	Soil Map Unit Points		Special Line Features
<b>Special Point Features</b>			Streams and Canals
	Blowout		Interstate Highways
	Borrow Pit		US Routes
	Clay Spot		Major Roads
	Closed Depression		Local Roads
	Gravel Pit		Aerial Photography
	Gravelly Spot		
	Landfill		
	Lava Flow		
	Marsh or swamp		
	Mine or Quarry		
	Miscellaneous Water		
	Perennial Water		
	Rock Outcrop		
	Saline Spot		
	Sandy Spot		
	Severely Eroded Spot		
	Sinkhole		
	Slide or Slip		
	Sodic Spot		

## MAP INFORMATION

The soil surveys that comprise your AOI were mapped at 1:24,000.

Warning: Soil Map may not be valid at this scale.

Enlargement of maps beyond the scale of mapping can cause misunderstanding of the detail of mapping and accuracy of soil line placement. The maps do not show the small areas of contrasting soils that could have been shown at a more detailed scale.

Please rely on the bar scale on each map sheet for map measurements.

Source of Map: Natural Resources Conservation Service  
 Web Soil Survey URL:  
 Coordinate System: Web Mercator (EPSG:3857)

Maps from the Web Soil Survey are based on the Web Mercator projection, which preserves direction and shape but distorts distance and area. A projection that preserves area, such as the Albers equal-area conic projection, should be used if more accurate calculations of distance or area are required.

This product is generated from the USDA-NRCS certified data as of the version date(s) listed below.

Soil Survey Area: Burlington County, New Jersey  
 Survey Area Data: Version 21, Sep 3, 2024

Soil map units are labeled (as space allows) for map scales 1:50,000 or larger.

Date(s) aerial images were photographed: Data not available.

The orthophoto or other base map on which the soil lines were compiled and digitized probably differs from the background imagery displayed on these maps. As a result, some minor shifting of map unit boundaries may be evident.

## Map Unit Legend

Map Unit Symbol	Map Unit Name	Acres in AOI	Percent of AOI
AdmkB	Adelphia fine sandy loam, clayey substratum, 2 to 5 percent slopes	0.2	1.1%
ComB	Collington fine sandy loam, 2 to 5 percent slopes	13.5	78.7%
MapB	Marlton fine sandy loam, 2 to 5 percent slopes	3.5	20.2%
<b>Totals for Area of Interest</b>		<b>17.1</b>	<b>100.0%</b>

## Map Unit Descriptions

The map units delineated on the detailed soil maps in a soil survey represent the soils or miscellaneous areas in the survey area. The map unit descriptions, along with the maps, can be used to determine the composition and properties of a unit.

A map unit delineation on a soil map represents an area dominated by one or more major kinds of soil or miscellaneous areas. A map unit is identified and named according to the taxonomic classification of the dominant soils. Within a taxonomic class there are precisely defined limits for the properties of the soils. On the landscape, however, the soils are natural phenomena, and they have the characteristic variability of all natural phenomena. Thus, the range of some observed properties may extend beyond the limits defined for a taxonomic class. Areas of soils of a single taxonomic class rarely, if ever, can be mapped without including areas of other taxonomic classes. Consequently, every map unit is made up of the soils or miscellaneous areas for which it is named and some minor components that belong to taxonomic classes other than those of the major soils.

Most minor soils have properties similar to those of the dominant soil or soils in the map unit, and thus they do not affect use and management. These are called noncontrasting, or similar, components. They may or may not be mentioned in a particular map unit description. Other minor components, however, have properties and behavioral characteristics divergent enough to affect use or to require different management. These are called contrasting, or dissimilar, components. They generally are in small areas and could not be mapped separately because of the scale used. Some small areas of strongly contrasting soils or miscellaneous areas are identified by a special symbol on the maps. If included in the database for a given area, the contrasting minor components are identified in the map unit descriptions along with some characteristics of each. A few areas of minor components may not have been observed, and consequently they are not mentioned in the descriptions, especially where the pattern was so complex that it was impractical to make enough observations to identify all the soils and miscellaneous areas on the landscape.

The presence of minor components in a map unit in no way diminishes the usefulness or accuracy of the data. The objective of mapping is not to delineate pure taxonomic classes but rather to separate the landscape into landforms or

## Custom Soil Resource Report

landform segments that have similar use and management requirements. The delineation of such segments on the map provides sufficient information for the development of resource plans. If intensive use of small areas is planned, however, onsite investigation is needed to define and locate the soils and miscellaneous areas.

An identifying symbol precedes the map unit name in the map unit descriptions. Each description includes general facts about the unit and gives important soil properties and qualities.

Soils that have profiles that are almost alike make up a *soil series*. Except for differences in texture of the surface layer, all the soils of a series have major horizons that are similar in composition, thickness, and arrangement.

Soils of one series can differ in texture of the surface layer, slope, stoniness, salinity, degree of erosion, and other characteristics that affect their use. On the basis of such differences, a soil series is divided into *soil phases*. Most of the areas shown on the detailed soil maps are phases of soil series. The name of a soil phase commonly indicates a feature that affects use or management. For example, Alpha silt loam, 0 to 2 percent slopes, is a phase of the Alpha series.

Some map units are made up of two or more major soils or miscellaneous areas. These map units are complexes, associations, or undifferentiated groups.

A *complex* consists of two or more soils or miscellaneous areas in such an intricate pattern or in such small areas that they cannot be shown separately on the maps. The pattern and proportion of the soils or miscellaneous areas are somewhat similar in all areas. Alpha-Beta complex, 0 to 6 percent slopes, is an example.

An *association* is made up of two or more geographically associated soils or miscellaneous areas that are shown as one unit on the maps. Because of present or anticipated uses of the map units in the survey area, it was not considered practical or necessary to map the soils or miscellaneous areas separately. The pattern and relative proportion of the soils or miscellaneous areas are somewhat similar. Alpha-Beta association, 0 to 2 percent slopes, is an example.

An *undifferentiated group* is made up of two or more soils or miscellaneous areas that could be mapped individually but are mapped as one unit because similar interpretations can be made for use and management. The pattern and proportion of the soils or miscellaneous areas in a mapped area are not uniform. An area can be made up of only one of the major soils or miscellaneous areas, or it can be made up of all of them. Alpha and Beta soils, 0 to 2 percent slopes, is an example.

Some surveys include *miscellaneous areas*. Such areas have little or no soil material and support little or no vegetation. Rock outcrop is an example.

## Burlington County, New Jersey

### AdmkB—Adelphia fine sandy loam, clayey substratum, 2 to 5 percent slopes

#### Map Unit Setting

*National map unit symbol:* rdy8  
*Elevation:* 10 to 120 feet  
*Mean annual precipitation:* 28 to 59 inches  
*Mean annual air temperature:* 46 to 79 degrees F  
*Frost-free period:* 161 to 231 days  
*Farmland classification:* All areas are prime farmland

#### Map Unit Composition

*Adelphia, clayey substratum, and similar soils:* 85 percent  
*Minor components:* 15 percent  
*Estimates are based on observations, descriptions, and transects of the mapunit.*

#### Description of Adelphia, Clayey Substratum

##### Setting

*Landform:* Low hills  
*Landform position (two-dimensional):* Backslope  
*Landform position (three-dimensional):* Interfluve  
*Down-slope shape:* Convex  
*Across-slope shape:* Linear  
*Parent material:* Glauconite bearing eolian deposits and/or glauconite bearing fluviomarine deposits; over clayey estuarine deposits

##### Typical profile

*Ap - 0 to 10 inches:* fine sandy loam  
*E - 10 to 14 inches:* fine sandy loam  
*Bt - 14 to 30 inches:* sandy clay loam  
*C - 30 to 40 inches:* stratified loamy sand to sandy loam  
*2C - 40 to 60 inches:* clay

##### Properties and qualities

*Slope:* 2 to 5 percent  
*Depth to restrictive feature:* More than 80 inches  
*Drainage class:* Moderately well drained  
*Runoff class:* Very high  
*Capacity of the most limiting layer to transmit water (Ksat):* Moderately low to moderately high (0.06 to 0.20 in/hr)  
*Depth to water table:* About 18 to 42 inches  
*Frequency of flooding:* None  
*Frequency of ponding:* None  
*Available water supply, 0 to 60 inches:* High (about 9.9 inches)

##### Interpretive groups

*Land capability classification (irrigated):* None specified  
*Land capability classification (nonirrigated):* 2w  
*Hydrologic Soil Group:* C  
*Ecological site:* F149AY130NJ - Moist Loamy Upland  
*Hydric soil rating:* No

**Minor Components**

**Keypoint**

*Percent of map unit:* 5 percent  
*Landform:* Knolls  
*Landform position (three-dimensional):* Side slope  
*Down-slope shape:* Convex  
*Across-slope shape:* Linear  
*Ecological site:* F149AY120MD - Moist Clayey Upland  
*Hydric soil rating:* No

**Shrewsbury**

*Percent of map unit:* 5 percent  
*Landform:* Flats  
*Down-slope shape:* Linear  
*Across-slope shape:* Linear  
*Ecological site:* F149AY090NJ - Coastal Plain Hardwood Swamp  
*Hydric soil rating:* Yes

**Collington**

*Percent of map unit:* 5 percent  
*Landform:* Low hills  
*Down-slope shape:* Linear  
*Across-slope shape:* Linear  
*Ecological site:* F149AY170MD - Well Drained Fine-Loamy Upland  
*Hydric soil rating:* No

**ComB—Collington fine sandy loam, 2 to 5 percent slopes**

**Map Unit Setting**

*National map unit symbol:* 2sql4  
*Elevation:* 0 to 220 feet  
*Mean annual precipitation:* 42 to 50 inches  
*Mean annual air temperature:* 50 to 57 degrees F  
*Frost-free period:* 190 to 250 days  
*Farmland classification:* All areas are prime farmland

**Map Unit Composition**

*Collington and similar soils:* 80 percent  
*Minor components:* 20 percent  
*Estimates are based on observations, descriptions, and transects of the mapunit.*

**Description of Collington**

**Setting**

*Landform:* Fluvio-marine terraces, flats  
*Landform position (two-dimensional):* Backslope  
*Landform position (three-dimensional):* Rise  
*Down-slope shape:* Convex, linear  
*Across-slope shape:* Linear

## Custom Soil Resource Report

*Parent material:* Glauconite bearing loamy fluviomarine deposits

### Typical profile

*Ap - 0 to 9 inches:* fine sandy loam  
*Bt1 - 9 to 19 inches:* loam  
*Bt2 - 19 to 31 inches:* loam  
*BC - 31 to 38 inches:* sandy loam  
*C - 38 to 80 inches:* sandy loam

### Properties and qualities

*Slope:* 2 to 5 percent  
*Depth to restrictive feature:* More than 80 inches  
*Drainage class:* Well drained  
*Runoff class:* Low  
*Capacity of the most limiting layer to transmit water (Ksat):* Moderately high to high  
(0.20 to 2.00 in/hr)  
*Depth to water table:* More than 80 inches  
*Frequency of flooding:* None  
*Frequency of ponding:* None  
*Maximum salinity:* Nonsaline to very slightly saline (0.0 to 2.0 mmhos/cm)  
*Available water supply, 0 to 60 inches:* Moderate (about 7.6 inches)

### Interpretive groups

*Land capability classification (irrigated):* 2e  
*Land capability classification (nonirrigated):* 2e  
*Hydrologic Soil Group:* B  
*Ecological site:* F149AY170MD - Well Drained Fine-Loamy Upland  
*Hydric soil rating:* No

### Minor Components

#### Adelphia

*Percent of map unit:* 4 percent  
*Landform:* Flats  
*Landform position (two-dimensional):* Backslope  
*Landform position (three-dimensional):* Rise  
*Down-slope shape:* Convex  
*Across-slope shape:* Linear  
*Ecological site:* F149AY130NJ - Moist Loamy Upland  
*Hydric soil rating:* No

#### Freehold

*Percent of map unit:* 4 percent  
*Landform:* Fluviomarine terraces, flats  
*Landform position (two-dimensional):* Backslope  
*Landform position (three-dimensional):* Rise  
*Down-slope shape:* Convex  
*Across-slope shape:* Linear  
*Ecological site:* F149AY170MD - Well Drained Fine-Loamy Upland  
*Hydric soil rating:* No

#### Reybold

*Percent of map unit:* 4 percent  
*Landform:* Fluviomarine terraces, flats  
*Landform position (two-dimensional):* Backslope  
*Landform position (three-dimensional):* Rise  
*Down-slope shape:* Convex, linear

## Custom Soil Resource Report

*Across-slope shape:* Linear  
*Ecological site:* F149AY170MD - Well Drained Fine-Loamy Upland  
*Hydric soil rating:* No

### **Shrewsbury, undrained**

*Percent of map unit:* 4 percent  
*Landform:* Flats  
*Landform position (two-dimensional):* Footslope  
*Landform position (three-dimensional):* Talf  
*Down-slope shape:* Linear  
*Across-slope shape:* Linear  
*Ecological site:* F149AY090NJ - Coastal Plain Hardwood Swamp  
*Hydric soil rating:* Yes

### **Tinton**

*Percent of map unit:* 4 percent  
*Landform:* Fluvio-marine terraces, flats  
*Landform position (two-dimensional):* Summit  
*Landform position (three-dimensional):* Tread, rise  
*Down-slope shape:* Linear  
*Across-slope shape:* Linear  
*Ecological site:* F153DY160NJ - Well Drained Coarse-Loamy Upland  
*Hydric soil rating:* No

## **MapB—Marlton fine sandy loam, 2 to 5 percent slopes**

### **Map Unit Setting**

*National map unit symbol:* rf4j  
*Elevation:* 20 to 160 feet  
*Mean annual precipitation:* 28 to 59 inches  
*Mean annual air temperature:* 46 to 79 degrees F  
*Frost-free period:* 161 to 231 days  
*Farmland classification:* All areas are prime farmland

### **Map Unit Composition**

*Marlton, well drained, and similar soils:* 90 percent  
*Minor components:* 10 percent  
*Estimates are based on observations, descriptions, and transects of the mapunit.*

### **Description of Marlton, Well Drained**

#### **Setting**

*Landform:* Flats, knolls  
*Landform position (three-dimensional):* Side slope  
*Down-slope shape:* Linear, convex  
*Across-slope shape:* Linear  
*Parent material:* Glauconitic clayey marine deposits

#### **Typical profile**

*Ap - 0 to 10 inches:* fine sandy loam  
*Bt - 10 to 30 inches:* clay loam

## Custom Soil Resource Report

*BC - 30 to 40 inches: clay loam*  
*C - 40 to 60 inches: sandy clay loam*

### **Properties and qualities**

*Slope: 2 to 5 percent*  
*Depth to restrictive feature: More than 80 inches*  
*Drainage class: Well drained*  
*Runoff class: Medium*  
*Capacity of the most limiting layer to transmit water (Ksat): Moderately low to moderately high (0.06 to 0.20 in/hr)*  
*Depth to water table: About 24 to 60 inches*  
*Frequency of flooding: None*  
*Frequency of ponding: None*  
*Available water supply, 0 to 60 inches: Moderate (about 8.1 inches)*

### **Interpretive groups**

*Land capability classification (irrigated): None specified*  
*Land capability classification (nonirrigated): 2e*  
*Hydrologic Soil Group: C*  
*Ecological site: F149AY100NJ - Moist Glauconitic Clayey Upland*  
*Hydric soil rating: No*

### **Minor Components**

#### **Collington**

*Percent of map unit: 5 percent*  
*Landform: Low hills*  
*Down-slope shape: Linear*  
*Across-slope shape: Linear*  
*Ecological site: F149AY170MD - Well Drained Fine-Loamy Upland*  
*Hydric soil rating: No*

#### **Adelphia, high glauconite**

*Percent of map unit: 5 percent*  
*Landform: Low hills*  
*Landform position (two-dimensional): Backslope*  
*Landform position (three-dimensional): Interfluve*  
*Down-slope shape: Convex*  
*Across-slope shape: Linear*  
*Ecological site: F149AY110NJ - Moist Glauconitic Fine-loamy Upland*  
*Hydric soil rating: No*



**FIGURE 2 – NEW JERSEY RAINFALL DISTRIBUTION REGIONS**



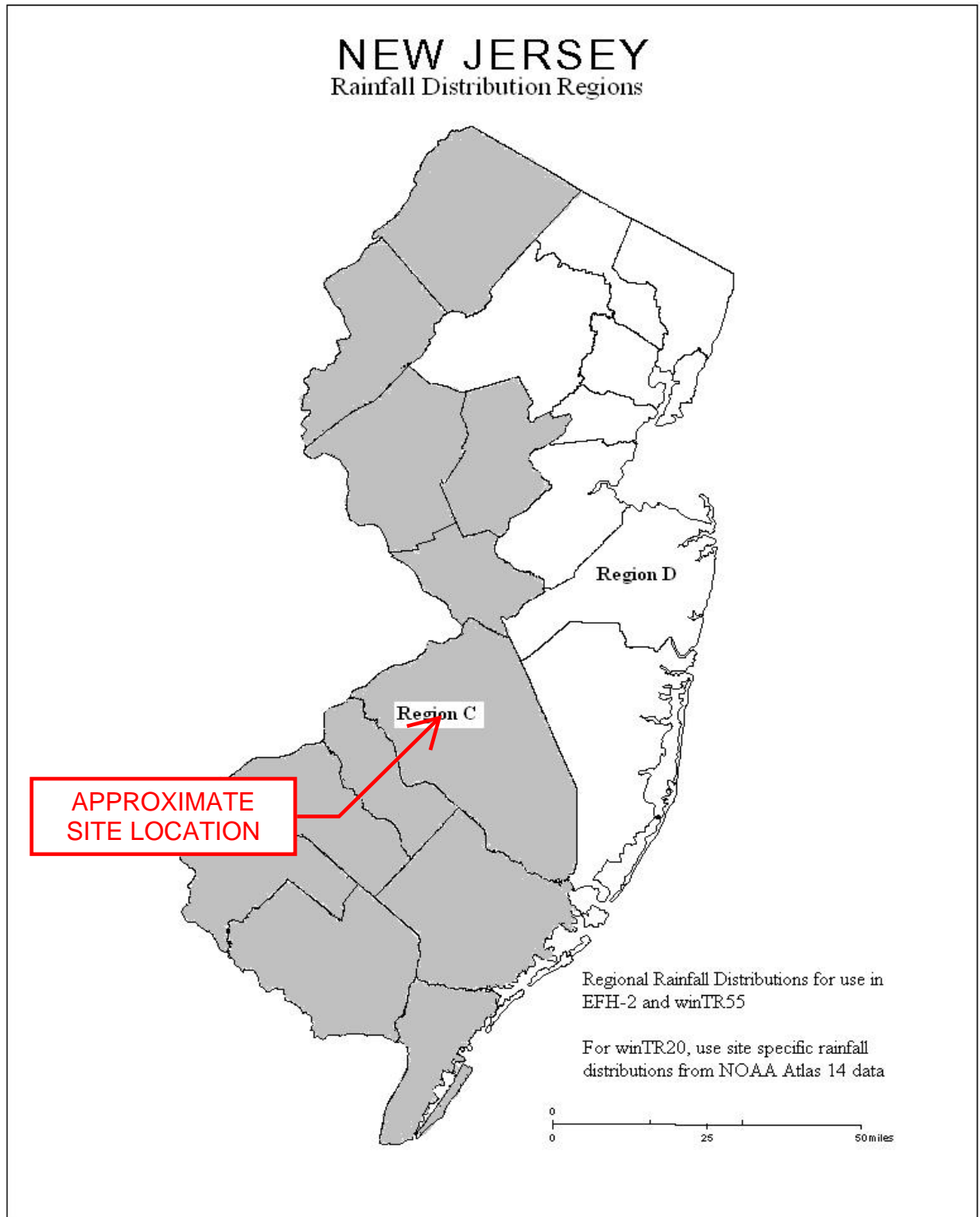



**FIGURE 3: NOAA RAINFALL DEPTH DATA**





**NOAA Atlas 14, Volume 2, Version 3**  
**Location name: Marlton, New Jersey, USA\***  
**Latitude: 39.8915°, Longitude: -74.9291°**  
**Elevation: 101 ft\*\***  
 \* source: ESRI Maps  
 \*\* source: USGS



**POINT PRECIPITATION FREQUENCY ESTIMATES**

G.M. Bonnin, D. Martin, B. Lin, T. Parzybok, M. Yekta, and D. Riley

NOAA, National Weather Service, Silver Spring, Maryland

[PF\\_tabular](#) | [PF\\_graphical](#) | [Maps & aeriels](#)

**PF tabular**

<b>PDS-based point precipitation frequency estimates with 90% confidence intervals (in inches)<sup>1</sup></b>										
Duration	Average recurrence interval (years)									
	1	2	5	10	25	50	100	200	500	1000
5-min	0.349 (0.318-0.383)	0.416 (0.379-0.456)	0.492 (0.448-0.539)	0.549 (0.498-0.601)	0.618 (0.558-0.677)	0.668 (0.601-0.733)	0.718 (0.643-0.790)	0.763 (0.679-0.844)	0.820 (0.721-0.913)	0.864 (0.753-0.969)
10-min	0.558 (0.509-0.611)	0.666 (0.607-0.729)	0.789 (0.718-0.864)	0.877 (0.797-0.962)	0.985 (0.890-1.08)	1.06 (0.957-1.17)	1.14 (1.02-1.26)	1.21 (1.08-1.34)	1.30 (1.14-1.44)	1.36 (1.19-1.53)
15-min	0.697 (0.636-0.764)	0.837 (0.763-0.917)	0.998 (0.908-1.09)	1.11 (1.01-1.22)	1.25 (1.13-1.37)	1.35 (1.21-1.48)	1.44 (1.29-1.59)	1.53 (1.36-1.69)	1.63 (1.44-1.82)	1.71 (1.49-1.92)
30-min	0.956 (0.872-1.05)	1.16 (1.05-1.27)	1.42 (1.29-1.55)	1.61 (1.46-1.76)	1.85 (1.67-2.03)	2.03 (1.82-2.23)	2.21 (1.98-2.43)	2.38 (2.11-2.63)	2.60 (2.28-2.89)	2.77 (2.41-3.10)
60-min	1.19 (1.09-1.31)	1.45 (1.32-1.59)	1.82 (1.65-1.99)	2.09 (1.90-2.30)	2.46 (2.22-2.70)	2.75 (2.47-3.02)	3.04 (2.72-3.35)	3.33 (2.96-3.68)	3.73 (3.28-4.15)	4.04 (3.52-4.53)
2-hr	1.44 (1.30-1.59)	1.75 (1.58-1.93)	2.20 (1.99-2.43)	2.56 (2.30-2.82)	3.03 (2.72-3.34)	3.41 (3.04-3.77)	3.80 (3.36-4.21)	4.19 (3.69-4.66)	4.74 (4.11-5.31)	5.17 (4.44-5.83)
3-hr	1.57 (1.43-1.74)	1.91 (1.73-2.12)	2.42 (2.18-2.67)	2.81 (2.53-3.11)	3.35 (3.00-3.71)	3.80 (3.38-4.20)	4.26 (3.75-4.73)	4.73 (4.13-5.27)	5.39 (4.63-6.05)	5.93 (5.03-6.68)
6-hr	1.97 (1.78-2.19)	2.38 (2.16-2.65)	3.00 (2.71-3.33)	3.50 (3.15-3.88)	4.22 (3.76-4.68)	4.82 (4.27-5.35)	5.46 (4.79-6.08)	6.15 (5.33-6.86)	7.13 (6.06-8.02)	7.96 (6.66-9.02)
12-hr	2.39 (2.17-2.67)	2.89 (2.62-3.23)	3.66 (3.31-4.08)	4.32 (3.89-4.80)	5.29 (4.71-5.88)	6.13 (5.41-6.82)	7.06 (6.14-7.87)	8.07 (6.92-9.05)	9.59 (8.02-10.8)	10.9 (8.94-12.4)
24-hr	2.75 (2.54-2.97)	3.32 (3.08-3.59)	4.25 (3.94-4.60)	5.04 (4.65-5.44)	6.21 (5.70-6.69)	7.23 (6.58-7.77)	8.36 (7.54-8.97)	9.61 (8.59-10.3)	11.5 (10.1-12.3)	13.1 (11.4-14.1)
2-day	3.16 (2.93-3.44)	3.84 (3.55-4.17)	4.91 (4.54-5.33)	5.82 (5.36-6.30)	7.14 (6.54-7.72)	8.28 (7.54-8.95)	9.53 (8.60-10.3)	10.9 (9.75-11.8)	12.9 (11.4-14.0)	14.7 (12.8-15.9)
3-day	3.34 (3.10-3.61)	4.04 (3.75-4.37)	5.14 (4.77-5.56)	6.07 (5.61-6.55)	7.42 (6.82-7.99)	8.57 (7.84-9.22)	9.83 (8.92-10.6)	11.2 (10.1-12.0)	13.2 (11.8-14.3)	14.9 (13.1-16.1)
4-day	3.50 (3.26-3.78)	4.24 (3.95-4.57)	5.37 (5.00-5.79)	6.32 (5.86-6.80)	7.70 (7.10-8.26)	8.86 (8.14-9.50)	10.1 (9.24-10.9)	11.5 (10.4-12.3)	13.5 (12.1-14.5)	15.2 (13.5-16.3)
7-day	4.09 (3.82-4.39)	4.92 (4.60-5.28)	6.15 (5.75-6.60)	7.18 (6.69-7.69)	8.68 (8.05-9.29)	9.94 (9.17-10.6)	11.3 (10.4-12.1)	12.8 (11.6-13.7)	14.9 (13.4-16.0)	16.7 (14.9-17.9)
10-day	4.64 (4.36-4.96)	5.56 (5.23-5.94)	6.86 (6.43-7.32)	7.91 (7.41-8.43)	9.41 (8.78-10.0)	10.6 (9.89-11.3)	11.9 (11.0-12.7)	13.3 (12.2-14.2)	15.3 (13.9-16.3)	17.0 (15.4-18.2)
20-day	6.29 (5.97-6.65)	7.48 (7.09-7.91)	8.98 (8.51-9.49)	10.2 (9.64-10.7)	11.8 (11.2-12.5)	13.1 (12.4-13.9)	14.5 (13.6-15.3)	15.8 (14.8-16.7)	17.7 (16.4-18.8)	19.2 (17.7-20.4)
30-day	7.81 (7.44-8.21)	9.23 (8.78-9.70)	10.9 (10.3-11.4)	12.2 (11.6-12.8)	13.9 (13.2-14.6)	15.2 (14.4-16.0)	16.6 (15.6-17.4)	17.9 (16.8-18.9)	19.7 (18.4-20.8)	21.1 (19.6-22.3)
45-day	9.96 (9.51-10.4)	11.7 (11.2-12.3)	13.6 (13.0-14.3)	15.0 (14.3-15.7)	16.9 (16.0-17.7)	18.2 (17.3-19.1)	19.6 (18.5-20.5)	20.8 (19.7-21.9)	22.5 (21.2-23.6)	23.7 (22.2-24.9)
60-day	11.9 (11.4-12.5)	14.0 (13.4-14.6)	16.1 (15.4-16.8)	17.6 (16.8-18.4)	19.6 (18.7-20.5)	21.0 (20.0-22.0)	22.4 (21.3-23.4)	23.6 (22.4-24.8)	25.2 (23.8-26.5)	26.3 (24.9-27.7)

<sup>1</sup> Precipitation frequency (PF) estimates in this table are based on frequency analysis of partial duration series (PDS). Numbers in parenthesis are PF estimates at lower and upper bounds of the 90% confidence interval. The probability that precipitation frequency estimates (for a given duration and average recurrence interval) will be greater than the upper bound (or less than the lower bound) is 5%. Estimates at upper bounds are not checked against probable maximum precipitation (PMP) estimates and may be higher than currently valid PMP values. Please refer to NOAA Atlas 14 document for more information.

[Back to Top](#)

**PF graphical**



**FIGURE 4: NOAA RAINFALL INTENSITY DATA**





**NOAA Atlas 14, Volume 2, Version 3**  
**Location name: Marlton, New Jersey, USA\***  
**Latitude: 39.8915°, Longitude: -74.9291°**  
**Elevation: 101 ft\*\***  
 \* source: ESRI Maps  
 \*\* source: USGS



**POINT PRECIPITATION FREQUENCY ESTIMATES**

G.M. Bonnin, D. Martin, B. Lin, T. Parzybok, M. Yekta, and D. Riley

NOAA, National Weather Service, Silver Spring, Maryland

[PF\\_tabular](#) | [PF\\_graphical](#) | [Maps & aerials](#)

**PF tabular**

<b>PDS-based point precipitation frequency estimates with 90% confidence intervals (in inches/hour)<sup>1</sup></b>										
Duration	Average recurrence interval (years)									
	1	2	5	10	25	50	100	200	500	1000
5-min	<b>4.19</b> (3.82-4.60)	<b>4.99</b> (4.55-5.47)	<b>5.90</b> (5.38-6.47)	<b>6.59</b> (5.98-7.21)	<b>7.42</b> (6.70-8.12)	<b>8.02</b> (7.21-8.80)	<b>8.62</b> (7.72-9.48)	<b>9.16</b> (8.15-10.1)	<b>9.84</b> (8.65-11.0)	<b>10.4</b> (9.04-11.6)
10-min	<b>3.35</b> (3.05-3.67)	<b>4.00</b> (3.64-4.37)	<b>4.73</b> (4.31-5.18)	<b>5.26</b> (4.78-5.77)	<b>5.91</b> (5.34-6.47)	<b>6.38</b> (5.74-7.01)	<b>6.85</b> (6.13-7.53)	<b>7.26</b> (6.46-8.02)	<b>7.78</b> (6.85-8.66)	<b>8.17</b> (7.12-9.16)
15-min	<b>2.79</b> (2.54-3.06)	<b>3.35</b> (3.05-3.67)	<b>3.99</b> (3.63-4.37)	<b>4.44</b> (4.03-4.86)	<b>4.99</b> (4.51-5.47)	<b>5.39</b> (4.84-5.91)	<b>5.77</b> (5.16-6.34)	<b>6.11</b> (5.43-6.75)	<b>6.53</b> (5.74-7.27)	<b>6.83</b> (5.96-7.66)
30-min	<b>1.91</b> (1.74-2.09)	<b>2.31</b> (2.11-2.53)	<b>2.83</b> (2.58-3.10)	<b>3.22</b> (2.92-3.53)	<b>3.70</b> (3.34-4.05)	<b>4.06</b> (3.65-4.45)	<b>4.42</b> (3.95-4.86)	<b>4.75</b> (4.23-5.25)	<b>5.19</b> (4.57-5.78)	<b>5.53</b> (4.82-6.20)
60-min	<b>1.19</b> (1.09-1.31)	<b>1.45</b> (1.32-1.59)	<b>1.82</b> (1.65-1.99)	<b>2.09</b> (1.90-2.30)	<b>2.46</b> (2.22-2.70)	<b>2.75</b> (2.47-3.02)	<b>3.04</b> (2.72-3.35)	<b>3.33</b> (2.96-3.68)	<b>3.73</b> (3.28-4.15)	<b>4.04</b> (3.52-4.53)
2-hr	<b>0.718</b> (0.651-0.794)	<b>0.874</b> (0.792-0.965)	<b>1.10</b> (0.996-1.22)	<b>1.28</b> (1.15-1.41)	<b>1.52</b> (1.36-1.67)	<b>1.70</b> (1.52-1.88)	<b>1.90</b> (1.68-2.10)	<b>2.10</b> (1.84-2.33)	<b>2.37</b> (2.06-2.65)	<b>2.58</b> (2.22-2.91)
3-hr	<b>0.524</b> (0.474-0.580)	<b>0.637</b> (0.577-0.704)	<b>0.804</b> (0.726-0.889)	<b>0.936</b> (0.843-1.04)	<b>1.12</b> (0.999-1.24)	<b>1.26</b> (1.12-1.40)	<b>1.42</b> (1.25-1.57)	<b>1.57</b> (1.37-1.75)	<b>1.79</b> (1.54-2.01)	<b>1.97</b> (1.68-2.22)
6-hr	<b>0.328</b> (0.297-0.365)	<b>0.397</b> (0.360-0.442)	<b>0.500</b> (0.452-0.555)	<b>0.584</b> (0.525-0.648)	<b>0.704</b> (0.628-0.781)	<b>0.804</b> (0.712-0.893)	<b>0.912</b> (0.799-1.01)	<b>1.03</b> (0.889-1.14)	<b>1.19</b> (1.01-1.34)	<b>1.33</b> (1.11-1.50)
12-hr	<b>0.198</b> (0.180-0.221)	<b>0.240</b> (0.217-0.267)	<b>0.303</b> (0.274-0.338)	<b>0.358</b> (0.322-0.398)	<b>0.439</b> (0.391-0.487)	<b>0.509</b> (0.449-0.566)	<b>0.585</b> (0.509-0.653)	<b>0.670</b> (0.574-0.751)	<b>0.795</b> (0.665-0.899)	<b>0.904</b> (0.742-1.03)
24-hr	<b>0.114</b> (0.106-0.123)	<b>0.138</b> (0.128-0.149)	<b>0.177</b> (0.164-0.191)	<b>0.209</b> (0.193-0.226)	<b>0.258</b> (0.237-0.278)	<b>0.301</b> (0.274-0.323)	<b>0.348</b> (0.314-0.373)	<b>0.400</b> (0.358-0.429)	<b>0.478</b> (0.421-0.514)	<b>0.545</b> (0.474-0.587)
2-day	<b>0.065</b> (0.060-0.071)	<b>0.079</b> (0.074-0.086)	<b>0.102</b> (0.094-0.111)	<b>0.121</b> (0.111-0.131)	<b>0.148</b> (0.136-0.160)	<b>0.172</b> (0.156-0.186)	<b>0.198</b> (0.179-0.214)	<b>0.227</b> (0.203-0.245)	<b>0.269</b> (0.237-0.291)	<b>0.305</b> (0.266-0.331)
3-day	<b>0.046</b> (0.042-0.050)	<b>0.056</b> (0.052-0.060)	<b>0.071</b> (0.066-0.077)	<b>0.084</b> (0.077-0.090)	<b>0.103</b> (0.094-0.110)	<b>0.119</b> (0.108-0.128)	<b>0.136</b> (0.123-0.146)	<b>0.155</b> (0.140-0.167)	<b>0.183</b> (0.163-0.197)	<b>0.207</b> (0.182-0.224)
4-day	<b>0.036</b> (0.034-0.039)	<b>0.044</b> (0.041-0.047)	<b>0.055</b> (0.052-0.060)	<b>0.065</b> (0.061-0.070)	<b>0.080</b> (0.074-0.086)	<b>0.092</b> (0.084-0.098)	<b>0.105</b> (0.096-0.113)	<b>0.119</b> (0.108-0.128)	<b>0.140</b> (0.126-0.151)	<b>0.158</b> (0.140-0.170)
7-day	<b>0.024</b> (0.022-0.026)	<b>0.029</b> (0.027-0.031)	<b>0.036</b> (0.034-0.039)	<b>0.042</b> (0.039-0.045)	<b>0.051</b> (0.047-0.055)	<b>0.059</b> (0.054-0.063)	<b>0.067</b> (0.061-0.071)	<b>0.076</b> (0.069-0.081)	<b>0.088</b> (0.079-0.095)	<b>0.099</b> (0.088-0.106)
10-day	<b>0.019</b> (0.018-0.020)	<b>0.023</b> (0.021-0.024)	<b>0.028</b> (0.026-0.030)	<b>0.032</b> (0.030-0.035)	<b>0.039</b> (0.036-0.041)	<b>0.044</b> (0.041-0.047)	<b>0.049</b> (0.045-0.052)	<b>0.055</b> (0.050-0.059)	<b>0.063</b> (0.058-0.068)	<b>0.070</b> (0.064-0.075)
20-day	<b>0.013</b> (0.012-0.013)	<b>0.015</b> (0.014-0.016)	<b>0.018</b> (0.017-0.019)	<b>0.021</b> (0.020-0.022)	<b>0.024</b> (0.023-0.026)	<b>0.027</b> (0.025-0.028)	<b>0.030</b> (0.028-0.031)	<b>0.033</b> (0.030-0.034)	<b>0.036</b> (0.034-0.039)	<b>0.040</b> (0.036-0.042)
30-day	<b>0.010</b> (0.010-0.011)	<b>0.012</b> (0.012-0.013)	<b>0.015</b> (0.014-0.015)	<b>0.016</b> (0.016-0.017)	<b>0.019</b> (0.018-0.020)	<b>0.021</b> (0.019-0.022)	<b>0.023</b> (0.021-0.024)	<b>0.024</b> (0.023-0.026)	<b>0.027</b> (0.025-0.028)	<b>0.029</b> (0.027-0.030)
45-day	<b>0.009</b> (0.008-0.009)	<b>0.010</b> (0.010-0.011)	<b>0.012</b> (0.012-0.013)	<b>0.013</b> (0.013-0.014)	<b>0.015</b> (0.014-0.016)	<b>0.016</b> (0.016-0.017)	<b>0.018</b> (0.017-0.018)	<b>0.019</b> (0.018-0.020)	<b>0.020</b> (0.019-0.021)	<b>0.021</b> (0.020-0.023)
60-day	<b>0.008</b> (0.007-0.008)	<b>0.009</b> (0.009-0.010)	<b>0.011</b> (0.010-0.011)	<b>0.012</b> (0.011-0.012)	<b>0.013</b> (0.012-0.014)	<b>0.014</b> (0.013-0.015)	<b>0.015</b> (0.014-0.016)	<b>0.016</b> (0.015-0.017)	<b>0.017</b> (0.016-0.018)	<b>0.018</b> (0.017-0.019)

<sup>1</sup> Precipitation frequency (PF) estimates in this table are based on frequency analysis of partial duration series (PDS). Numbers in parenthesis are PF estimates at lower and upper bounds of the 90% confidence interval. The probability that precipitation frequency estimates (for a given duration and average recurrence interval) will be greater than the upper bound (or less than the lower bound) is 5%. Estimates at upper bounds are not checked against probable maximum precipitation (PMP) estimates and may be higher than currently valid PMP values. Please refer to NOAA Atlas 14 document for more information.

[Back to Top](#)

**PF graphical**



**APPENDIX B: PRE-CONSTRUCTION STORM ROUTINGS**



**Existing Conditions-Current**

NOAA 24-hr C 2-Year (Current) Rainfall=3.29"

Prepared by Taylor, Wiseman, Taylor Printed 8/27/2025  
HydroCAD® 10.20-2h s/n 04583 © 2024 HydroCAD Software Solutions LLC Page 2

Time span=0.00-48.00 hrs, dt=0.05 hrs, 961 points  
Runoff by SCS TR-20 method, UH=Delmarva, Split Pervious/Imperv.  
Reach routing by Stor-Ind+Trans method - Pond routing by Stor-Ind method

**Subcatchment 1S: E-1 Impervious** Runoff Area=5.186 ac 100.00% Impervious Runoff Depth=3.06"  
Flow Length=528' Tc=4.4 min CN=0/98 Runoff=15.70 cfs 1.321 af

**Subcatchment 2S: E-2 Impervious** Runoff Area=0.422 ac 100.00% Impervious Runoff Depth=3.06"  
Flow Length=237' Slope=0.0100 1' Tc=2.7 min CN=0/98 Runoff=1.45 cfs 0.108 af

**Subcatchment 3S: E-1 Pervious** Runoff Area=3.282 ac 0.00% Impervious Runoff Depth=0.69"  
Flow Length=428' Tc=12.2 min CN=66/0 Runoff=1.36 cfs 0.188 af

**Subcatchment 4S: E-2 Pervious** Runoff Area=0.219 ac 0.00% Impervious Runoff Depth=0.48"  
Flow Length=43' Slope=0.0900 1' Tc=2.7 min CN=61/0 Runoff=0.10 cfs 0.009 af

**Link 6L: POA #1** Inflow=16.49 cfs 1.510 af  
Primary=16.49 cfs 1.510 af

**Link 7L: POA #2** Inflow=1.55 cfs 0.116 af  
Primary=1.55 cfs 0.116 af

**Total Runoff Area = 9.109 ac Runoff Volume = 1.626 af Average Runoff Depth = 2.14"**  
38.43% Pervious = 3.501 ac 61.57% Impervious = 5.608 ac

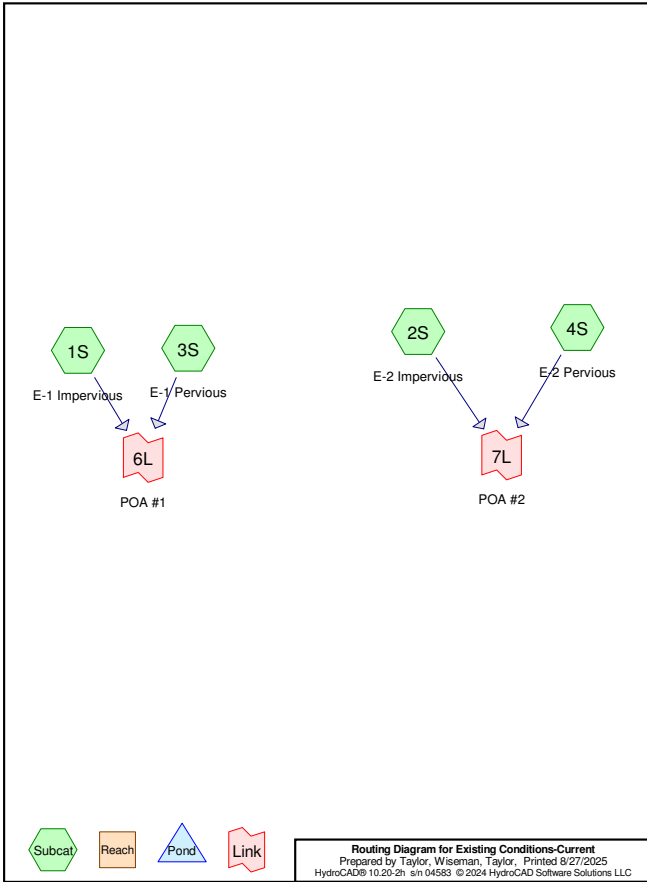

**Existing Conditions-Current**

NOAA 24-hr C 2-Year (Current) Rainfall=3.29"

Prepared by Taylor, Wiseman, Taylor Printed 8/27/2025  
HydroCAD® 10.20-2h s/n 04583 © 2024 HydroCAD Software Solutions LLC Page 3

**Summary for Subcatchment 1S: E-1 Impervious**

Runoff = 15.70 cfs @ 12.12 hrs, Volume= 1.321 af, Depth= 3.06"  
Routed to Link 6L : POA #1

Runoff by SCS TR-20 method, UH=Delmarva, Split Pervious/Imperv., Time Span= 0.00-48.00 hrs, dt= 0.05 hrs  
NOAA 24-hr C 2-Year (Current) Rainfall=3.29"

Area (ac)	CN	Description
5.186	98	
5.186	98	100.00% Impervious Area

Tc (min)	Length (feet)	Slope (ft/ft)	Velocity (ft/sec)	Capacity (cfs)	Description
1.6	100	0.0100	1.06		Sheet Flow, Segment 1 Smooth surfaces n= 0.011 P2= 3.29"
2.8	428	0.0160	2.57		Shallow Concentrated Flow, Segment 2 Paved Kv= 20.3 fps
4.4	528	Total			

**Subcatchment 1S: E-1 Impervious**

Hydrograph

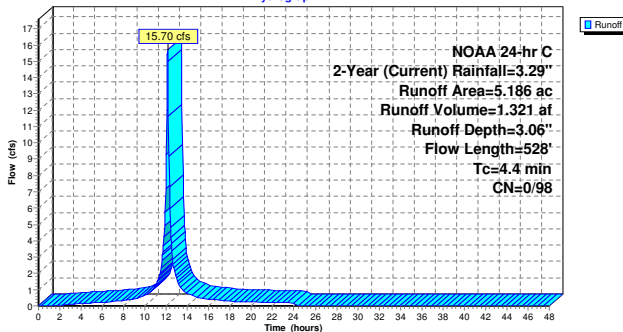

**Existing Conditions-Current**

NOAA 24-hr C 2-Year (Current) Rainfall=3.29"

Prepared by Taylor, Wiseman, Taylor Printed 8/27/2025  
HydroCAD® 10.20-2h s/n 04583 © 2024 HydroCAD Software Solutions LLC Page 4

**Summary for Subcatchment 2S: E-2 Impervious**

Runoff = 1.45 cfs @ 12.10 hrs, Volume= 0.108 af, Depth= 3.06"  
Routed to Link 7L : POA #2

Runoff by SCS TR-20 method, UH=Delmarva, Split Pervious/Imperv., Time Span= 0.00-48.00 hrs, dt= 0.05 hrs  
NOAA 24-hr C 2-Year (Current) Rainfall=3.29"

Area (ac)	CN	Description
0.422	98	
0.422	98	100.00% Impervious Area

Tc (min)	Length (feet)	Slope (ft/ft)	Velocity (ft/sec)	Capacity (cfs)	Description
1.6	100	0.0100	1.06		Sheet Flow, Smooth surfaces n= 0.011 P2= 3.29"
1.1	137	0.0100	2.03		Shallow Concentrated Flow, Paved Kv= 20.3 fps
2.7	237	Total			

**Subcatchment 2S: E-2 Impervious**

Hydrograph

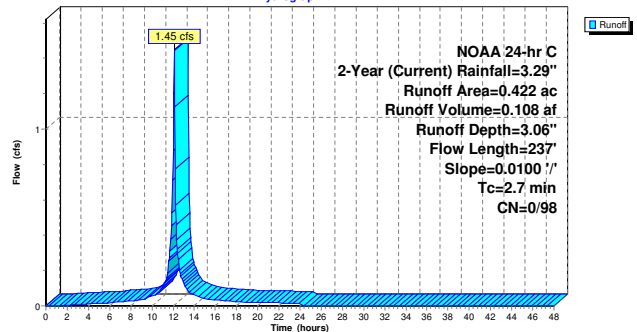

**Summary for Subcatchment 3S: E-1 Pervious**

Runoff = 1.36 cfs @ 12.27 hrs, Volume= 0.188 af, Depth= 0.69"  
 Routed to Link 6L : POA #1

Runoff by SCS TR-20 method, UH=Delmarva, Split Pervious/Imperv., Time Span= 0.00-48.00 hrs, dt= 0.05 hrs  
 NOAA 24-hr C 2-Year (Current) Rainfall=3.29"

Area (ac)	CN	Description
1.997	61	>75% Grass cover, Good, HSG B
1.285	74	>75% Grass cover, Good, HSG C
3.282	66	Weighted Average
3.282	66	100.00% Pervious Area

Tc (min)	Length (feet)	Slope (ft/ft)	Velocity (ft/sec)	Capacity (cfs)	Description
9.7	100	0.0200	0.17		Sheet Flow, Grass: Short n= 0.150 P2= 3.29"
2.5	328	0.0180	2.16		Shallow Concentrated Flow, Unpaved Kv= 16.1 fps
12.2	428				Total

**Subcatchment 3S: E-1 Pervious**

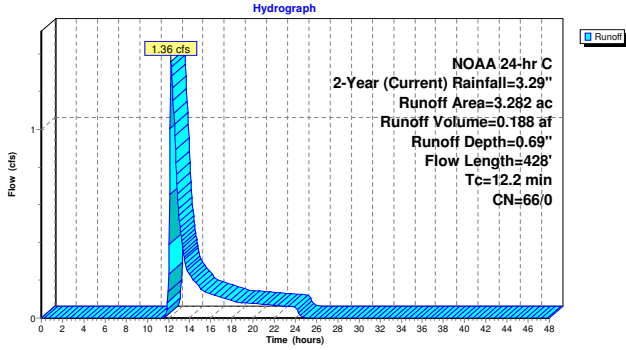

**Summary for Subcatchment 4S: E-2 Pervious**

Runoff = 0.10 cfs @ 12.12 hrs, Volume= 0.009 af, Depth= 0.48"  
 Routed to Link 7L : POA #2

Runoff by SCS TR-20 method, UH=Delmarva, Split Pervious/Imperv., Time Span= 0.00-48.00 hrs, dt= 0.05 hrs  
 NOAA 24-hr C 2-Year (Current) Rainfall=3.29"

Area (ac)	CN	Description
0.219	61	>75% Grass cover, Good, HSG B
0.219	61	100.00% Pervious Area

Tc (min)	Length (feet)	Slope (ft/ft)	Velocity (ft/sec)	Capacity (cfs)	Description
2.7	43	0.0900	0.27		Sheet Flow, Grass: Short n= 0.150 P2= 3.29"

**Subcatchment 4S: E-2 Pervious**

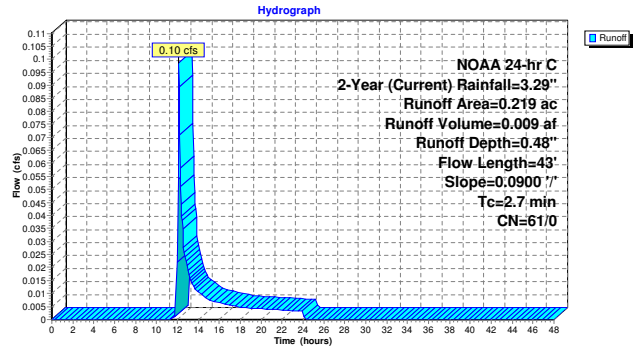

**Summary for Link 6L: POA #1**

Inflow Area = 8.468 ac, 61.24% Impervious, Inflow Depth = 2.14" for 2-Year (Current) event  
 Inflow = 16.49 cfs @ 12.12 hrs, Volume= 1.510 af  
 Primary = 16.49 cfs @ 12.12 hrs, Volume= 1.510 af, Atten= 0%, Lag= 0.0 min  
 Routed to nonexistent node 9L

Primary outflow = Inflow, Time Span= 0.00-48.00 hrs, dt= 0.05 hrs

**Link 6L: POA #1**

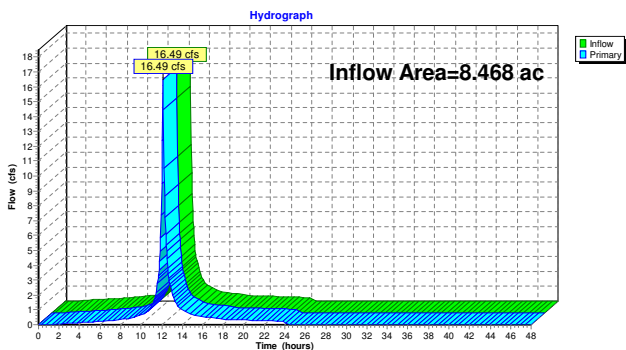

**Summary for Link 7L: POA #2**

Inflow Area = 0.641 ac, 65.83% Impervious, Inflow Depth = 2.18" for 2-Year (Current) event  
 Inflow = 1.55 cfs @ 12.10 hrs, Volume= 0.116 af  
 Primary = 1.55 cfs @ 12.10 hrs, Volume= 0.116 af, Atten= 0%, Lag= 0.0 min  
 Routed to nonexistent node 9L

Primary outflow = Inflow, Time Span= 0.00-48.00 hrs, dt= 0.05 hrs

**Link 7L: POA #2**

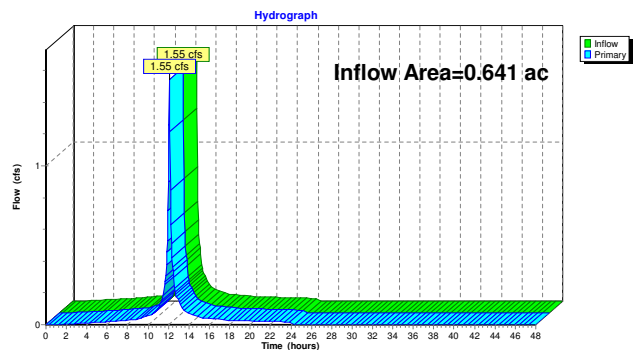

Time span=0.00-48.00 hrs, dt=0.05 hrs, 961 points  
 Runoff by SCS TR-20 method, UH=Delmarva, Split Pervious/Imperv.  
 Reach routing by Stor-Ind+Trans method - Pond routing by Stor-Ind method

**Subcatchment 1S: E-1 Impervious** Runoff Area=5.186 ac 100.00% Impervious Runoff Depth=4.85"  
 Flow Length=528' Tc=4.4 min CN=0/98 Runoff=24.46 cfs 2.097 af

**Subcatchment 2S: E-2 Impervious** Runoff Area=0.422 ac 100.00% Impervious Runoff Depth=4.85"  
 Flow Length=237' Slope=0.0100 /' Tc=2.7 min CN=0/98 Runoff=2.26 cfs 0.171 af

**Subcatchment 3S: E-1 Pervious** Runoff Area=3.282 ac 0.00% Impervious Runoff Depth=1.79"  
 Flow Length=428' Tc=12.2 min CN=66/0 Runoff=4.18 cfs 0.489 af

**Subcatchment 4S: E-2 Pervious** Runoff Area=0.219 ac 0.00% Impervious Runoff Depth=1.42"  
 Flow Length=43' Slope=0.0900 /' Tc=2.7 min CN=61/0 Runoff=0.38 cfs 0.026 af

**Link 6L: POA #1** Inflow=27.32 cfs 2.587 af  
 Primary=27.32 cfs 2.587 af

**Link 7L: POA #2** Inflow=2.64 cfs 0.197 af  
 Primary=2.64 cfs 0.197 af

**Total Runoff Area = 9.109 ac Runoff Volume = 2.783 af Average Runoff Depth = 3.67"**  
**38.43% Pervious = 3.501 ac 61.57% Impervious = 5.608 ac**

**Summary for Subcatchment 1S: E-1 Impervious**

Runoff = 24.46 cfs @ 12.12 hrs, Volume= 2.097 af, Depth= 4.85"  
 Routed to Link 6L : POA #1

Runoff by SCS TR-20 method, UH=Delmarva, Split Pervious/Imperv., Time Span= 0.00-48.00 hrs, dt= 0.05 hrs  
 NOAA 24-hr C 10-Year (Current) Rainfall=5.09"

Area (ac)	CN	Description
* 5.186	98	
5.186	98	100.00% Impervious Area

Tc (min)	Length (feet)	Slope (ft/ft)	Velocity (ft/sec)	Capacity (cfs)	Description
1.6	100	0.0100	1.06		Sheet Flow, Segment 1 Smooth surfaces n= 0.011 P2= 3.29"
2.8	428	0.0160	2.57		Shallow Concentrated Flow, Segment 2 Paved Kv= 20.3 fps
4.4	528	Total			

**Subcatchment 1S: E-1 Impervious**

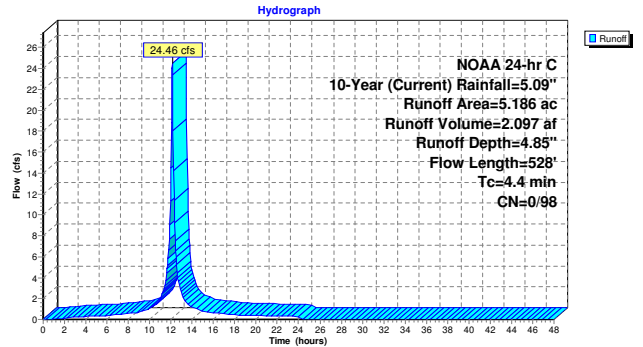

**Summary for Subcatchment 2S: E-2 Impervious**

Runoff = 2.26 cfs @ 12.10 hrs, Volume= 0.171 af, Depth= 4.85"  
 Routed to Link 7L : POA #2

Runoff by SCS TR-20 method, UH=Delmarva, Split Pervious/Imperv., Time Span= 0.00-48.00 hrs, dt= 0.05 hrs  
 NOAA 24-hr C 10-Year (Current) Rainfall=5.09"

Area (ac)	CN	Description
* 0.422	98	
0.422	98	100.00% Impervious Area

Tc (min)	Length (feet)	Slope (ft/ft)	Velocity (ft/sec)	Capacity (cfs)	Description
1.6	100	0.0100	1.06		Sheet Flow, Smooth surfaces n= 0.011 P2= 3.29"
1.1	137	0.0100	2.03		Shallow Concentrated Flow, Paved Kv= 20.3 fps
2.7	237	Total			

**Subcatchment 2S: E-2 Impervious**

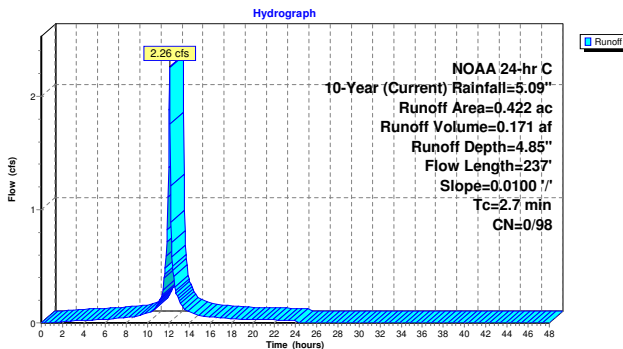

**Summary for Subcatchment 3S: E-1 Pervious**

Runoff = 4.18 cfs @ 12.24 hrs, Volume= 0.489 af, Depth= 1.79"  
 Routed to Link 6L : POA #1

Runoff by SCS TR-20 method, UH=Delmarva, Split Pervious/Imperv., Time Span= 0.00-48.00 hrs, dt= 0.05 hrs  
 NOAA 24-hr C 10-Year (Current) Rainfall=5.09"

Area (ac)	CN	Description
1.997	61	>75% Grass cover, Good, HSG B
1.285	74	>75% Grass cover, Good, HSG C
3.282	66	Weighted Average
3.282	66	100.00% Pervious Area

Tc (min)	Length (feet)	Slope (ft/ft)	Velocity (ft/sec)	Capacity (cfs)	Description
9.7	100	0.0200	0.17		Sheet Flow, Grass: Short n= 0.150 P2= 3.29"
2.5	328	0.0180	2.16		Shallow Concentrated Flow, Unpaved Kv= 16.1 fps
12.2	428	Total			

**Subcatchment 3S: E-1 Pervious**

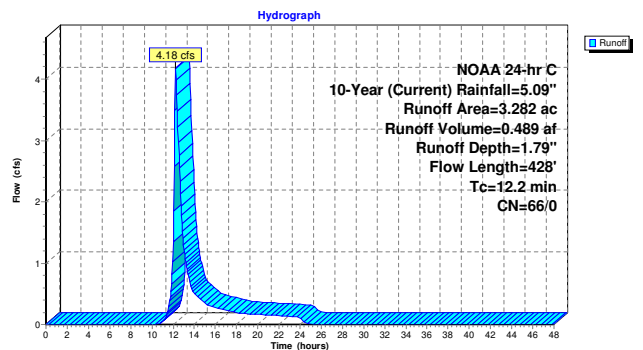

**Summary for Subcatchment 4S: E-2 Pervious**

Runoff = 0.38 cfs @ 12.11 hrs, Volume= 0.026 af, Depth= 1.42"  
 Routed to Link 7L : POA #2

Runoff by SCS TR-20 method, UH=Delmarva, Split Pervious/Imperv., Time Span= 0.00-48.00 hrs, dt= 0.05 hrs  
 NOAA 24-hr C 10-Year (Current) Rainfall=5.09"

Area (ac)	CN	Description
0.219	61	>75% Grass cover, Good, HSG B
0.219	61	100.00% Pervious Area

To (min)	Length (feet)	Slope (ft/ft)	Velocity (ft/sec)	Capacity (cfs)	Description
2.7	43	0.0900	0.27		Sheet Flow, Grass: Short n= 0.150 P2= 3.29"

**Subcatchment 4S: E-2 Pervious**

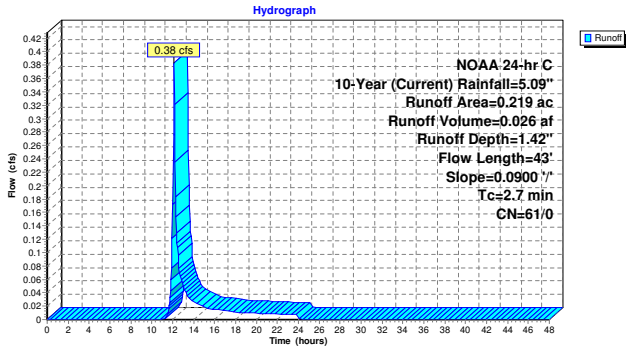

**Summary for Link 6L: POA #1**

Inflow Area = 8.468 ac, 61.24% Impervious, Inflow Depth = 3.67" for 10-Year (Current) event  
 Inflow = 27.32 cfs @ 12.13 hrs, Volume= 2.587 af  
 Primary = 27.32 cfs @ 12.13 hrs, Volume= 2.587 af, Atten= 0%, Lag= 0.0 min  
 Routed to nonexistent node 9L

Primary outflow = Inflow, Time Span= 0.00-48.00 hrs, dt= 0.05 hrs

**Link 6L: POA #1**

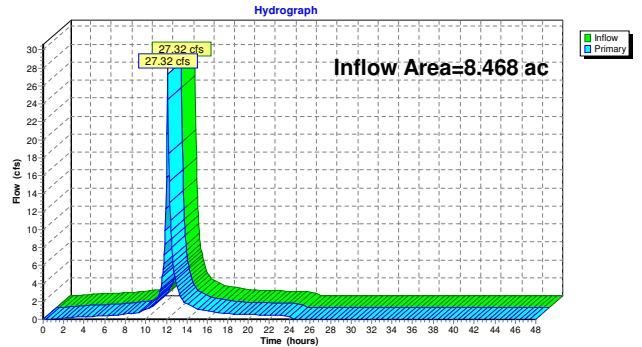

**Summary for Link 7L: POA #2**

Inflow Area = 0.641 ac, 65.83% Impervious, Inflow Depth = 3.68" for 10-Year (Current) event  
 Inflow = 2.64 cfs @ 12.10 hrs, Volume= 0.197 af  
 Primary = 2.64 cfs @ 12.10 hrs, Volume= 0.197 af, Atten= 0%, Lag= 0.0 min  
 Routed to nonexistent node 9L

Primary outflow = Inflow, Time Span= 0.00-48.00 hrs, dt= 0.05 hrs

**Link 7L: POA #2**

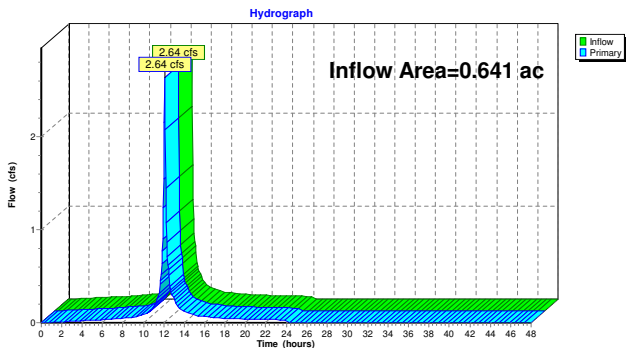

Time span=0.00-48.00 hrs, dt=0.05 hrs, 961 points  
 Runoff by SCS TR-20 method, UH=Delmarva, Split Pervious/Imperv.  
 Reach routing by Stor-Ind+Trans method - Pond routing by Stor-Ind method

**Subcatchment 1S: E-1 Impervious** Runoff Area=5.186 ac 100.00% Impervious Runoff Depth=8.45"  
 Flow Length=528' Tc=4.4 min CN=0/98 Runoff=41.92 cfs 3.652 af

**Subcatchment 2S: E-2 Impervious** Runoff Area=0.422 ac 100.00% Impervious Runoff Depth=8.45"  
 Flow Length=237' Slope=0.0100 1/1 Tc=2.7 min CN=0/98 Runoff=3.87 cfs 0.297 af

**Subcatchment 3S: E-1 Pervious** Runoff Area=3.282 ac 0.00% Impervious Runoff Depth=4.58"  
 Flow Length=428' Tc=12.2 min CN=66/0 Runoff=11.33 cfs 1.253 af

**Subcatchment 4S: E-2 Pervious** Runoff Area=0.219 ac 0.00% Impervious Runoff Depth=3.98"  
 Flow Length=43' Slope=0.0900 1/1 Tc=2.7 min CN=61/0 Runoff=1.13 cfs 0.073 af

**Link 6L: POA #1** Inflow=50.44 cfs 4.904 af  
 Primary=50.44 cfs 4.904 af

**Link 7L: POA #2** Inflow=5.00 cfs 0.370 af  
 Primary=5.00 cfs 0.370 af

**Total Runoff Area = 9.109 ac Runoff Volume = 5.274 af Average Runoff Depth = 6.95"**  
**38.43% Pervious = 3.501 ac 61.57% Impervious = 5.608 ac**

**Summary for Subcatchment 1S: E-1 Impervious**

Runoff = 41.92 cfs @ 12.12 hrs, Volume= 3.652 af, Depth= 8.45"  
 Routed to Link 6L : POA #1

Runoff by SCS TR-20 method, UH=Delmarva, Split Pervious/Imperv., Time Span= 0.00-48.00 hrs, dt= 0.05 hrs  
 NOAA 24-hr C 100-Year (Current) Rainfall=8.69"

Area (ac)	CN	Description
5.186	98	
5.186	98	100.00% Impervious Area

Tc (min)	Length (feet)	Slope (ft/ft)	Velocity (ft/sec)	Capacity (cfs)	Description
1.6	100	0.0100	1.06		Sheet Flow, Segment 1 Smooth surfaces n= 0.011 P2= 3.29"
2.8	428	0.0160	2.57		Shallow Concentrated Flow, Segment 2 Paved Kv= 20.3 fps
4.4	528				Total

**Subcatchment 1S: E-1 Impervious**

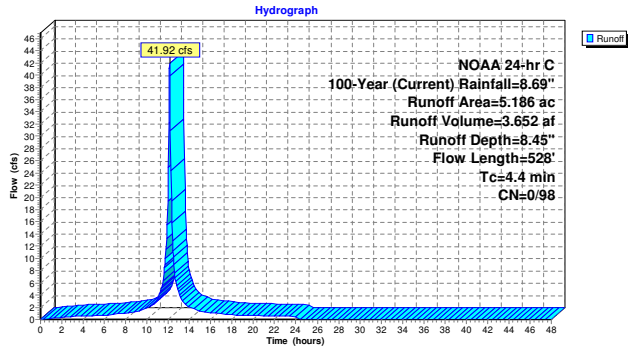

**Summary for Subcatchment 2S: E-2 Impervious**

Runoff = 3.87 cfs @ 12.10 hrs, Volume= 0.297 af, Depth= 8.45"  
 Routed to Link 7L : POA #2

Runoff by SCS TR-20 method, UH=Delmarva, Split Pervious/Imperv., Time Span= 0.00-48.00 hrs, dt= 0.05 hrs  
 NOAA 24-hr C 100-Year (Current) Rainfall=8.69"

Area (ac)	CN	Description
0.422	98	
0.422	98	100.00% Impervious Area

Tc (min)	Length (feet)	Slope (ft/ft)	Velocity (ft/sec)	Capacity (cfs)	Description
1.6	100	0.0100	1.06		Sheet Flow, Smooth surfaces n= 0.011 P2= 3.29"
1.1	137	0.0100	2.03		Shallow Concentrated Flow, Paved Kv= 20.3 fps
2.7	237				Total

**Subcatchment 2S: E-2 Impervious**

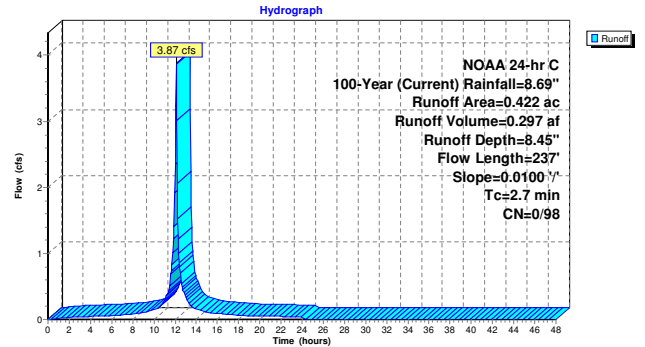

**Summary for Subcatchment 3S: E-1 Pervious**

Runoff = 11.33 cfs @ 12.22 hrs, Volume= 1.253 af, Depth= 4.58"  
 Routed to Link 6L : POA #1

Runoff by SCS TR-20 method, UH=Delmarva, Split Pervious/Imperv., Time Span= 0.00-48.00 hrs, dt= 0.05 hrs  
 NOAA 24-hr C 100-Year (Current) Rainfall=8.69"

Area (ac)	CN	Description
1.997	61	>75% Grass cover, Good, HSG B
1.285	74	>75% Grass cover, Good, HSG C
3.282	66	Weighted Average
3.282	66	100.00% Pervious Area

Tc (min)	Length (feet)	Slope (ft/ft)	Velocity (ft/sec)	Capacity (cfs)	Description
9.7	100	0.0200	0.17		Sheet Flow, Grass: Short n= 0.150 P2= 3.29"
2.5	328	0.0180	2.16		Shallow Concentrated Flow, Unpaved Kv= 16.1 fps
12.2	428				Total

**Subcatchment 3S: E-1 Pervious**

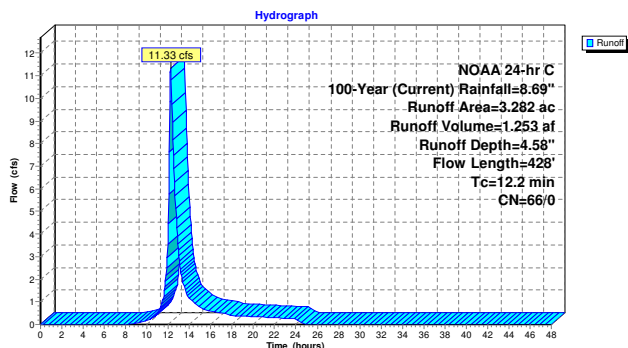

**Summary for Subcatchment 4S: E-2 Pervious**

Runoff = 1.13 cfs @ 12.10 hrs, Volume= 0.073 af, Depth= 3.98"  
 Routed to Link 7L : POA #2

Runoff by SCS TR-20 method, UH=Delmarva, Split Pervious/Imperv., Time Span= 0.00-48.00 hrs, dt= 0.05 hrs  
 NOAA 24-hr C 100-Year (Current) Rainfall=8.69"

Area (ac)	CN	Description
0.219	61	>75% Grass cover, Good, HSG B
0.219	61	100.00% Pervious Area

Tc (min)	Length (feet)	Slope (ft/ft)	Velocity (ft/sec)	Capacity (cfs)	Description
2.7	43	0.0900	0.27		Sheet Flow, Grass: Short n= 0.150 P2= 3.29"

**Subcatchment 4S: E-2 Pervious**

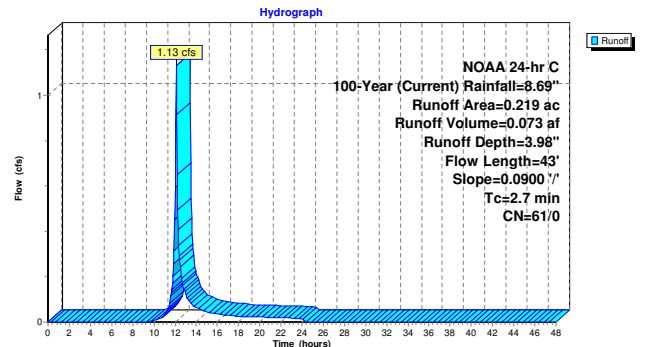

**Existing Conditions-Current**

NOAA 24-hr C 100-Year (Current) Rainfall=8.69"

Prepared by Taylor, Wiseman, Taylor  
HydroCAD® 10.20-2h s/n 04583 © 2024 HydroCAD Software Solutions LLC

Printed 8/27/2025  
Page 21

**Summary for Link 6L: POA #1**

Inflow Area = 8.468 ac, 61.24% Impervious, Inflow Depth = 6.95" for 100-Year (Current) event  
Inflow = 50.44 cfs @ 12.13 hrs, Volume= 4.904 af  
Primary = 50.44 cfs @ 12.13 hrs, Volume= 4.904 af, Atten= 0%, Lag= 0.0 min  
Routed to nonexistent node 9L

Primary outflow = Inflow, Time Span= 0.00-48.00 hrs, dt= 0.05 hrs

**Link 6L: POA #1**

Hydrograph

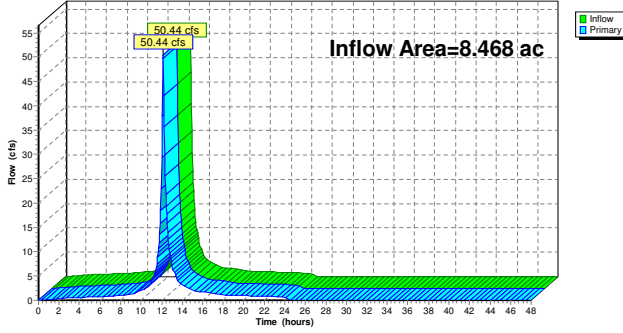

**Existing Conditions-Current**

NOAA 24-hr C 100-Year (Current) Rainfall=8.69"

Prepared by Taylor, Wiseman, Taylor  
HydroCAD® 10.20-2h s/n 04583 © 2024 HydroCAD Software Solutions LLC

Printed 8/27/2025  
Page 22

**Summary for Link 7L: POA #2**

Inflow Area = 0.641 ac, 65.83% Impervious, Inflow Depth = 6.92" for 100-Year (Current) event  
Inflow = 5.00 cfs @ 12.10 hrs, Volume= 0.370 af  
Primary = 5.00 cfs @ 12.10 hrs, Volume= 0.370 af, Atten= 0%, Lag= 0.0 min  
Routed to nonexistent node 9L

Primary outflow = Inflow, Time Span= 0.00-48.00 hrs, dt= 0.05 hrs

**Link 7L: POA #2**

Hydrograph

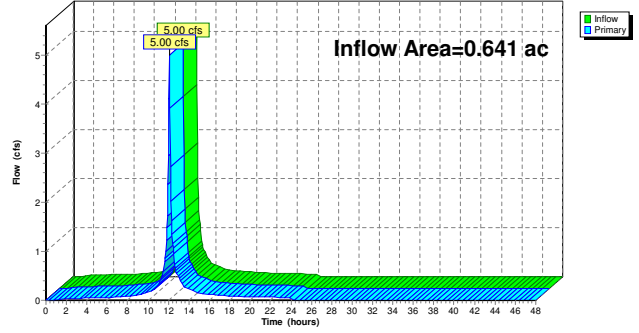

Time span=0.00-48.00 hrs, dt=0.05 hrs, 961 points  
 Runoff by SCS TR-20 method, UH=Delmarva, Split Pervious/Imperv.  
 Reach routing by Stor-Ind+Trans method - Pond routing by Stor-Ind method

**Subcatchment 1S: E-1 Impervious** Runoff Area=5.186 ac 100.00% Impervious Runoff Depth=3.65"  
 Flow Length=528' Tc=4.3 min CN=0/98 Runoff=18.71 cfs 1.575 af

**Subcatchment 2S: E-2 Impervious** Runoff Area=0.422 ac 100.00% Impervious Runoff Depth=3.65"  
 Flow Length=237' Slope=0.0100 1' Tc=2.6 min CN=0/98 Runoff=1.73 cfs 0.128 af

**Subcatchment 3S: E-1 Pervious** Runoff Area=3.282 ac 0.00% Impervious Runoff Depth=1.01"  
 Flow Length=428' Tc=11.4 min CN=66/0 Runoff=2.26 cfs 0.278 af

**Subcatchment 4S: E-2 Pervious** Runoff Area=0.219 ac 0.00% Impervious Runoff Depth=0.75"  
 Flow Length=43' Slope=0.0900 1' Tc=2.5 min CN=61/0 Runoff=0.19 cfs 0.014 af

**Link 6L: POA #1** Inflow=20.24 cfs 1.853 af  
 Primary=20.24 cfs 1.853 af

**Link 7L: POA #2** Inflow=1.91 cfs 0.142 af  
 Primary=1.91 cfs 0.142 af

**Total Runoff Area = 9.109 ac Runoff Volume = 1.995 af Average Runoff Depth = 2.63"**  
**38.43% Pervious = 3.501 ac 61.57% Impervious = 5.608 ac**

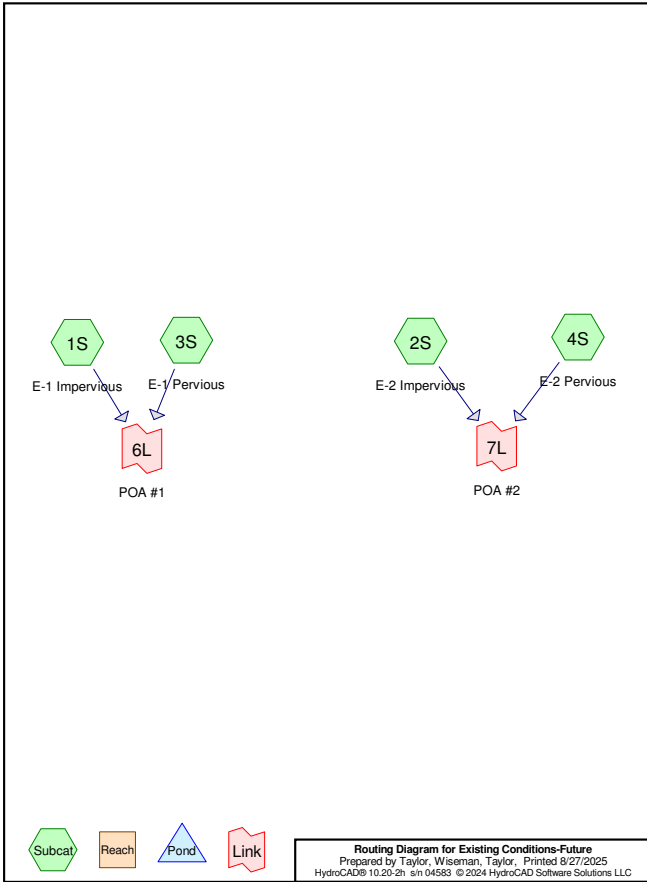

**Summary for Subcatchment 1S: E-1 Impervious**

Runoff = 18.71 cfs @ 12.12 hrs, Volume= 1.575 af, Depth= 3.65"  
 Routed to Link 6L : POA #1

Runoff by SCS TR-20 method, UH=Delmarva, Split Pervious/Imperv., Time Span= 0.00-48.00 hrs, dt= 0.05 hrs  
 NOAA 24-hr C 2-Year (Future) Rainfall=3.88"

Area (ac)	CN	Description
5.186	98	
5.186	98	100.00% Impervious Area

Tc (min)	Length (feet)	Slope (ft/ft)	Velocity (ft/sec)	Capacity (cfs)	Description
1.5	100	0.0100	1.15		Sheet Flow, Segment 1 Smooth surfaces n= 0.011 P2= 3.88"
2.8	428	0.0160	2.57		Shallow Concentrated Flow, Segment 2 Paved Kv= 20.3 fps
4.3	528	Total			

**Subcatchment 1S: E-1 Impervious**

Hydrograph

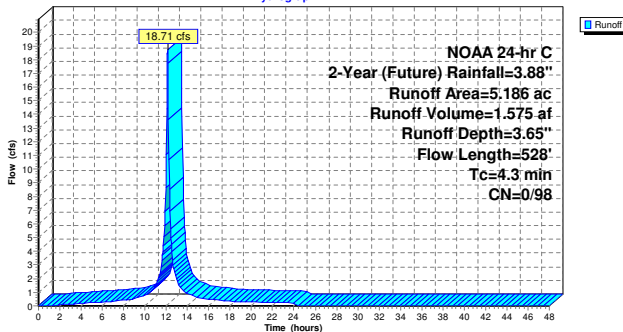

**Summary for Subcatchment 2S: E-2 Impervious**

Runoff = 1.73 cfs @ 12.10 hrs, Volume= 0.128 af, Depth= 3.65"  
 Routed to Link 7L : POA #2

Runoff by SCS TR-20 method, UH=Delmarva, Split Pervious/Imperv., Time Span= 0.00-48.00 hrs, dt= 0.05 hrs  
 NOAA 24-hr C 2-Year (Future) Rainfall=3.88"

Area (ac)	CN	Description
0.422	98	
0.422	98	100.00% Impervious Area

Tc (min)	Length (feet)	Slope (ft/ft)	Velocity (ft/sec)	Capacity (cfs)	Description
1.5	100	0.0100	1.15		Sheet Flow, Smooth surfaces n= 0.011 P2= 3.88"
1.1	137	0.0100	2.03		Shallow Concentrated Flow, Paved Kv= 20.3 fps
2.6	237	Total			

**Subcatchment 2S: E-2 Impervious**

Hydrograph

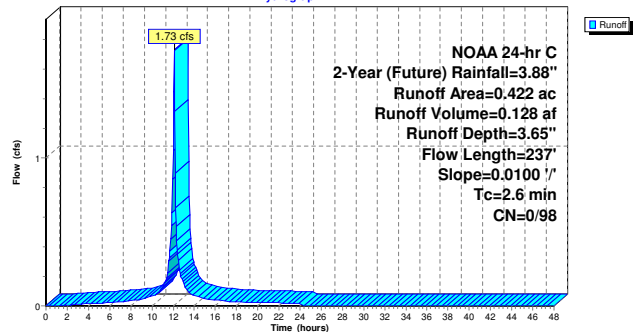

Summary for Subcatchment 3S: E-1 Pervious

Runoff = 2.26 cfs @ 12.24 hrs, Volume= 0.278 af, Depth= 1.01"  
 Routed to Link 6L : POA #1

Runoff by SCS TR-20 method, UH=Delmarva, Split Pervious/Imperv., Time Span= 0.00-48.00 hrs, dt= 0.05 hrs  
 NOAA 24-hr C 2-Year (Future) Rainfall=3.88"

Area (ac)	CN	Description
1.997	61	>75% Grass cover, Good, HSG B
1.285	74	>75% Grass cover, Good, HSG C
3.282	66	Weighted Average
3.282	66	100.00% Pervious Area

Tc (min)	Length (feet)	Slope (ft/ft)	Velocity (ft/sec)	Capacity (cfs)	Description
8.9	100	0.0200	0.19		Sheet Flow, Grass: Short n= 0.150 P2= 3.88"
2.5	328	0.0180	2.16		Shallow Concentrated Flow, Unpaved Kv= 16.1 fps
11.4	428				Total

Subcatchment 3S: E-1 Pervious

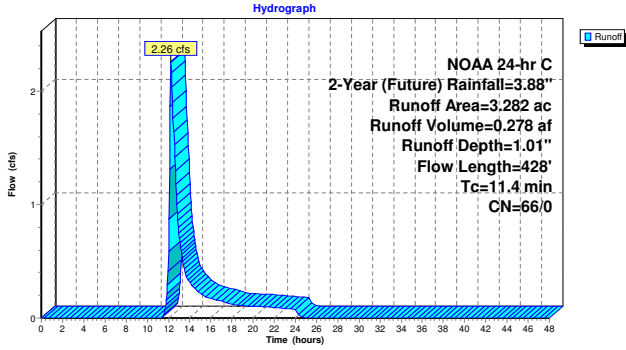

Summary for Subcatchment 4S: E-2 Pervious

Runoff = 0.19 cfs @ 12.11 hrs, Volume= 0.014 af, Depth= 0.75"  
 Routed to Link 7L : POA #2

Runoff by SCS TR-20 method, UH=Delmarva, Split Pervious/Imperv., Time Span= 0.00-48.00 hrs, dt= 0.05 hrs  
 NOAA 24-hr C 2-Year (Future) Rainfall=3.88"

Area (ac)	CN	Description
0.219	61	>75% Grass cover, Good, HSG B
0.219	61	100.00% Pervious Area

Tc (min)	Length (feet)	Slope (ft/ft)	Velocity (ft/sec)	Capacity (cfs)	Description
2.5	43	0.0900	0.29		Sheet Flow, Grass: Short n= 0.150 P2= 3.88"

Subcatchment 4S: E-2 Pervious

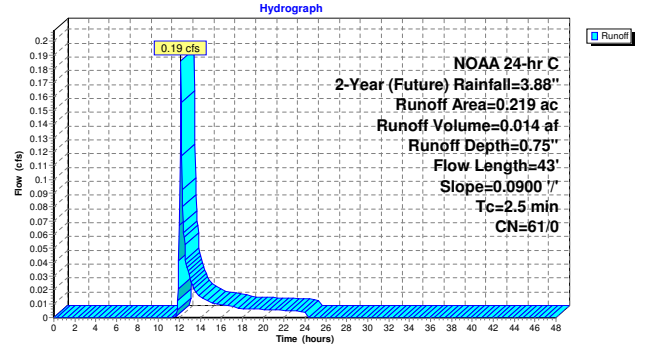

Summary for Link 6L: POA #1

Inflow Area = 8.468 ac, 61.24% Impervious, Inflow Depth = 2.63" for 2-Year (Future) event  
 Inflow = 20.24 cfs @ 12.12 hrs, Volume= 1.853 af  
 Primary = 20.24 cfs @ 12.12 hrs, Volume= 1.853 af, Atten= 0%, Lag= 0.0 min  
 Routed to nonexistent node 9L

Primary outflow = Inflow, Time Span= 0.00-48.00 hrs, dt= 0.05 hrs

Link 6L: POA #1

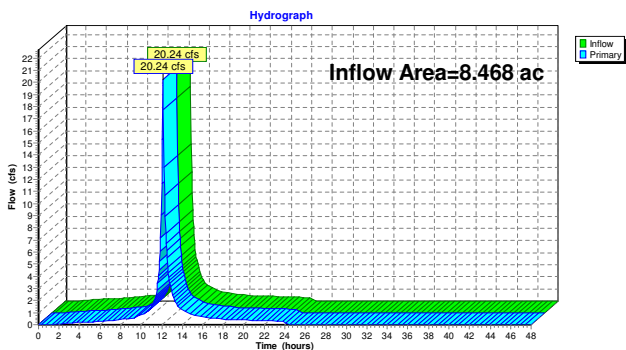

Summary for Link 7L: POA #2

Inflow Area = 0.641 ac, 65.83% Impervious, Inflow Depth = 2.66" for 2-Year (Future) event  
 Inflow = 1.91 cfs @ 12.10 hrs, Volume= 0.142 af  
 Primary = 1.91 cfs @ 12.10 hrs, Volume= 0.142 af, Atten= 0%, Lag= 0.0 min  
 Routed to nonexistent node 9L

Primary outflow = Inflow, Time Span= 0.00-48.00 hrs, dt= 0.05 hrs

Link 7L: POA #2

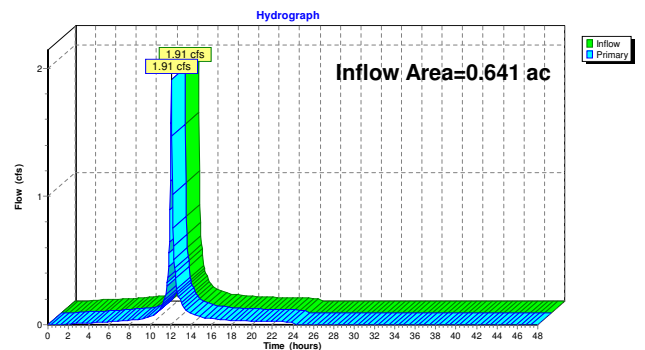

Time span=0.00-48.00 hrs, dt=0.05 hrs, 961 points  
 Runoff by SCS TR-20 method, UH=Delmarva, Split Pervious/Imperv.  
 Reach routing by Stor-Ind+Trans method - Pond routing by Stor-Ind method

**Subcatchment 1S: E-1 Impervious** Runoff Area=5.186 ac 100.00% Impervious Runoff Depth=5.71"  
 Flow Length=528' Tc=4.3 min CN=0/98 Runoff=28.84 cfs 2.468 af

**Subcatchment 2S: E-2 Impervious** Runoff Area=0.422 ac 100.00% Impervious Runoff Depth=5.71"  
 Flow Length=237' Slope=0.0100 /' Tc=2.6 min CN=0/98 Runoff=2.67 cfs 0.201 af

**Subcatchment 3S: E-1 Pervious** Runoff Area=3.282 ac 0.00% Impervious Runoff Depth=2.40"  
 Flow Length=428' Tc=11.4 min CN=66/0 Runoff=6.00 cfs 0.657 af

**Subcatchment 4S: E-2 Pervious** Runoff Area=0.219 ac 0.00% Impervious Runoff Depth=1.97"  
 Flow Length=43' Slope=0.0900 /' Tc=2.5 min CN=61/0 Runoff=0.56 cfs 0.036 af

**Link 6L: POA #1** Inflow=33.16 cfs 3.126 af  
 Primary=33.16 cfs 3.126 af

**Link 7L: POA #2** Inflow=3.22 cfs 0.237 af  
 Primary=3.22 cfs 0.237 af

**Total Runoff Area = 9.109 ac Runoff Volume = 3.363 af Average Runoff Depth = 4.43"**  
**38.43% Pervious = 3.501 ac 61.57% Impervious = 5.608 ac**

**Summary for Subcatchment 1S: E-1 Impervious**

Runoff = 28.84 cfs @ 12.12 hrs, Volume= 2.468 af, Depth= 5.71"  
 Routed to Link 6L : POA #1

Runoff by SCS TR-20 method, UH=Delmarva, Split Pervious/Imperv., Time Span= 0.00-48.00 hrs, dt= 0.05 hrs  
 NOAA 24-hr C 10-Year (Future) Rainfall=5.95"

Area (ac)	CN	Description
* 5.186	98	
5.186	98	100.00% Impervious Area

Tc (min)	Length (feet)	Slope (ft/ft)	Velocity (ft/sec)	Capacity (cfs)	Description
1.5	100	0.0100	1.15		Sheet Flow, Segment 1 Smooth surfaces n= 0.011 P2= 3.88"
2.8	428	0.0160	2.57		Shallow Concentrated Flow, Segment 2 Paved Kv= 20.3 fps
4.3	528	Total			

**Subcatchment 1S: E-1 Impervious**

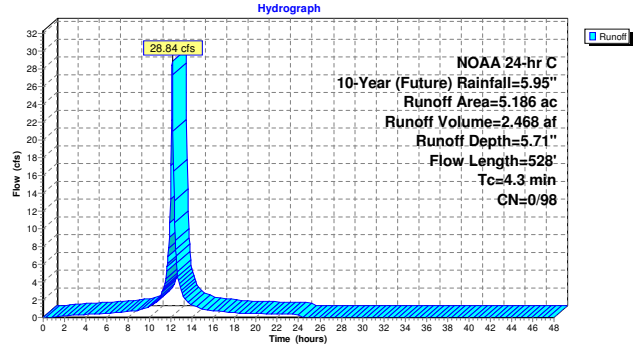

**Summary for Subcatchment 2S: E-2 Impervious**

Runoff = 2.67 cfs @ 12.10 hrs, Volume= 0.201 af, Depth= 5.71"  
 Routed to Link 7L : POA #2

Runoff by SCS TR-20 method, UH=Delmarva, Split Pervious/Imperv., Time Span= 0.00-48.00 hrs, dt= 0.05 hrs  
 NOAA 24-hr C 10-Year (Future) Rainfall=5.95"

Area (ac)	CN	Description
* 0.422	98	
0.422	98	100.00% Impervious Area

Tc (min)	Length (feet)	Slope (ft/ft)	Velocity (ft/sec)	Capacity (cfs)	Description
1.5	100	0.0100	1.15		Sheet Flow, Smooth surfaces n= 0.011 P2= 3.88"
1.1	137	0.0100	2.03		Shallow Concentrated Flow, Paved Kv= 20.3 fps
2.6	237	Total			

**Subcatchment 2S: E-2 Impervious**

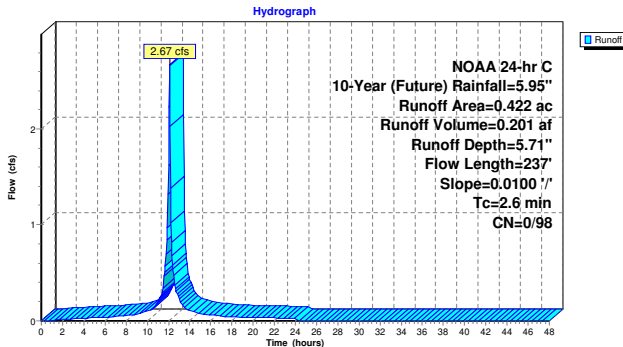

**Summary for Subcatchment 3S: E-1 Pervious**

Runoff = 6.00 cfs @ 12.22 hrs, Volume= 0.657 af, Depth= 2.40"  
 Routed to Link 6L : POA #1

Runoff by SCS TR-20 method, UH=Delmarva, Split Pervious/Imperv., Time Span= 0.00-48.00 hrs, dt= 0.05 hrs  
 NOAA 24-hr C 10-Year (Future) Rainfall=5.95"

Area (ac)	CN	Description
1.997	61	>75% Grass cover, Good, HSG B
1.285	74	>75% Grass cover, Good, HSG C
3.282	66	Weighted Average
3.282	66	100.00% Pervious Area

Tc (min)	Length (feet)	Slope (ft/ft)	Velocity (ft/sec)	Capacity (cfs)	Description
8.9	100	0.0200	0.19		Sheet Flow, Grass: Short n= 0.150 P2= 3.88"
2.5	328	0.0180	2.16		Shallow Concentrated Flow, Unpaved Kv= 16.1 fps
11.4	428	Total			

**Subcatchment 3S: E-1 Pervious**

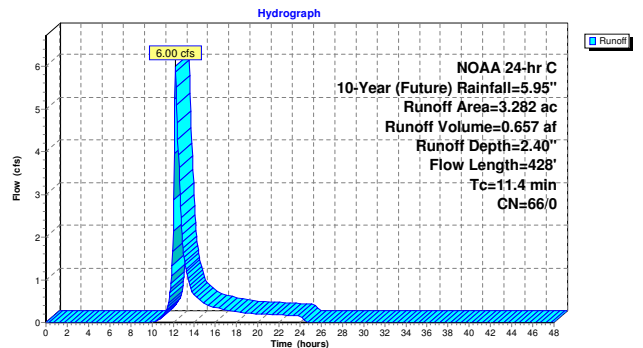

**Summary for Subcatchment 4S: E-2 Pervious**

Runoff = 0.56 cfs @ 12.10 hrs, Volume= 0.036 af, Depth= 1.97"  
 Routed to Link 7L : POA #2

Runoff by SCS TR-20 method, UH=Delmarva, Split Pervious/Imperv., Time Span= 0.00-48.00 hrs, dt= 0.05 hrs  
 NOAA 24-hr C 10-Year (Future) Rainfall=5.95"

Area (ac)	CN	Description
0.219	61	>75% Grass cover, Good, HSG B
0.219	61	100.00% Pervious Area

Tc (min)	Length (feet)	Slope (ft/ft)	Velocity (ft/sec)	Capacity (cfs)	Description
2.5	43	0.0900	0.29		Sheet Flow, Grass: Short n= 0.150 P2= 3.88"

**Subcatchment 4S: E-2 Pervious**

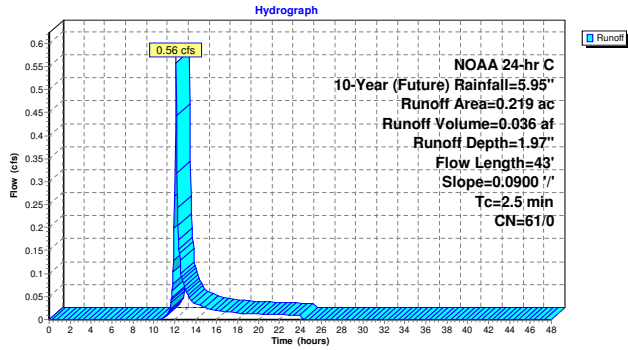

**Summary for Link 6L: POA #1**

Inflow Area = 8.468 ac, 61.24% Impervious, Inflow Depth = 4.43" for 10-Year (Future) event  
 Inflow = 33.16 cfs @ 12.13 hrs, Volume= 3.126 af  
 Primary = 33.16 cfs @ 12.13 hrs, Volume= 3.126 af, Atten= 0%, Lag= 0.0 min  
 Routed to nonexistent node 9L

Primary outflow = Inflow, Time Span= 0.00-48.00 hrs, dt= 0.05 hrs

**Link 6L: POA #1**

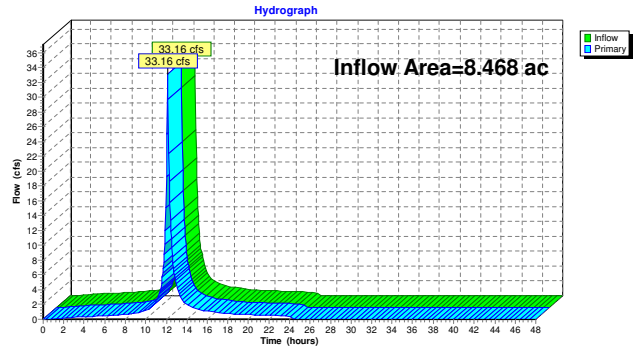

**Summary for Link 7L: POA #2**

Inflow Area = 0.641 ac, 65.83% Impervious, Inflow Depth = 4.43" for 10-Year (Future) event  
 Inflow = 3.22 cfs @ 12.10 hrs, Volume= 0.237 af  
 Primary = 3.22 cfs @ 12.10 hrs, Volume= 0.237 af, Atten= 0%, Lag= 0.0 min  
 Routed to nonexistent node 9L

Primary outflow = Inflow, Time Span= 0.00-48.00 hrs, dt= 0.05 hrs

**Link 7L: POA #2**

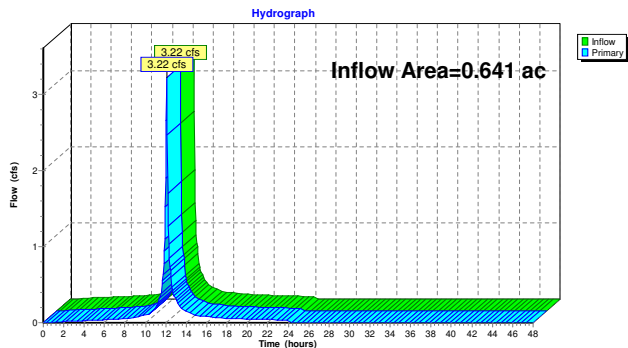

Time span=0.00-48.00 hrs, dt=0.05 hrs, 961 points  
 Runoff by SCS TR-20 method, UH=Delmarva, Split Pervious/Imperv.  
 Reach routing by Stor-Ind+Trans method - Pond routing by Stor-Ind method

**Subcatchment 1S: E-1 Impervious** Runoff Area=5.186 ac 100.00% Impervious Runoff Depth=10.80"  
 Flow Length=528' Tc=4.3 min CN=0/98 Runoff=53.66 cfs 4.667 af

**Subcatchment 2S: E-2 Impervious** Runoff Area=0.422 ac 100.00% Impervious Runoff Depth=10.80"  
 Flow Length=237' Slope=0.0100 /' Tc=2.6 min CN=0/98 Runoff=4.96 cfs 0.380 af

**Subcatchment 3S: E-1 Pervious** Runoff Area=3.282 ac 0.00% Impervious Runoff Depth=6.61"  
 Flow Length=428' Tc=11.4 min CN=66/0 Runoff=16.95 cfs 1.807 af

**Subcatchment 4S: E-2 Pervious** Runoff Area=0.219 ac 0.00% Impervious Runoff Depth=5.90"  
 Flow Length=43' Slope=0.0900 /' Tc=2.5 min CN=61/0 Runoff=1.70 cfs 0.108 af

**Link 6L: POA #1** Inflow=66.96 cfs 6.474 af  
 Primary=66.96 cfs 6.474 af

**Link 7L: POA #2** Inflow=6.66 cfs 0.487 af  
 Primary=6.66 cfs 0.487 af

**Total Runoff Area = 9.109 ac Runoff Volume = 6.962 af Average Runoff Depth = 9.17"**  
**38.43% Pervious = 3.501 ac 61.57% Impervious = 5.608 ac**

**Summary for Subcatchment 1S: E-1 Impervious**

Runoff = 53.66 cfs @ 12.12 hrs, Volume= 4.667 af, Depth=10.80"  
 Routed to Link 6L : POA #1

Runoff by SCS TR-20 method, UH=Delmarva, Split Pervious/Imperv., Time Span= 0.00-48.00 hrs, dt= 0.05 hrs  
 NOAA 24-hr C 100-Year (Future) Rainfall=11.04"

Area (ac)	CN	Description
5.186	98	
5.186	98	100.00% Impervious Area

Tc (min)	Length (feet)	Slope (ft/ft)	Velocity (ft/sec)	Capacity (cfs)	Description
1.5	100	0.0100	1.15		Sheet Flow, Segment 1 Smooth surfaces n= 0.011 P2= 3.88"
2.8	428	0.0160	2.57		Shallow Concentrated Flow, Segment 2 Paved Kv= 20.3 fps
4.3	528				Total

**Subcatchment 1S: E-1 Impervious**

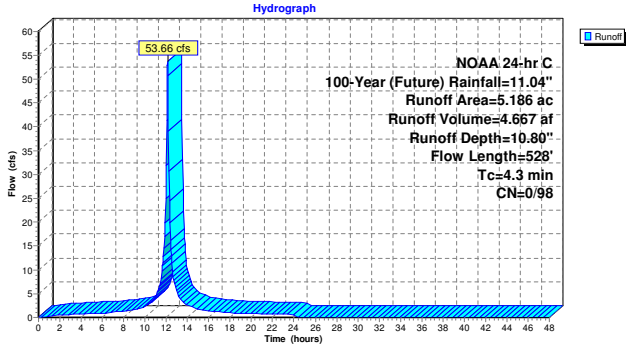

**Summary for Subcatchment 2S: E-2 Impervious**

Runoff = 4.96 cfs @ 12.10 hrs, Volume= 0.380 af, Depth=10.80"  
 Routed to Link 7L : POA #2

Runoff by SCS TR-20 method, UH=Delmarva, Split Pervious/Imperv., Time Span= 0.00-48.00 hrs, dt= 0.05 hrs  
 NOAA 24-hr C 100-Year (Future) Rainfall=11.04"

Area (ac)	CN	Description
0.422	98	
0.422	98	100.00% Impervious Area

Tc (min)	Length (feet)	Slope (ft/ft)	Velocity (ft/sec)	Capacity (cfs)	Description
1.5	100	0.0100	1.15		Sheet Flow, Smooth surfaces n= 0.011 P2= 3.88"
1.1	137	0.0100	2.03		Shallow Concentrated Flow, Paved Kv= 20.3 fps
2.6	237				Total

**Subcatchment 2S: E-2 Impervious**

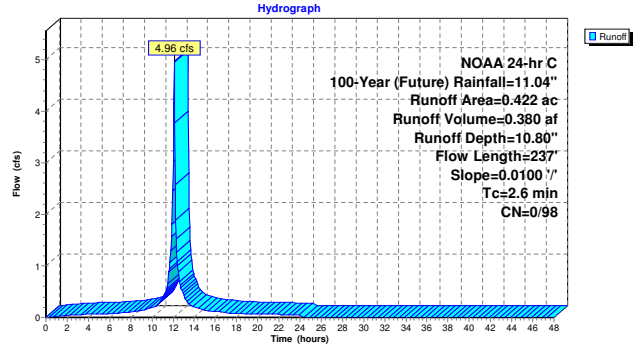

**Summary for Subcatchment 3S: E-1 Pervious**

Runoff = 16.95 cfs @ 12.21 hrs, Volume= 1.807 af, Depth= 6.61"  
 Routed to Link 6L : POA #1

Runoff by SCS TR-20 method, UH=Delmarva, Split Pervious/Imperv., Time Span= 0.00-48.00 hrs, dt= 0.05 hrs  
 NOAA 24-hr C 100-Year (Future) Rainfall=11.04"

Area (ac)	CN	Description
1.997	61	>75% Grass cover, Good, HSG B
1.285	74	>75% Grass cover, Good, HSG C
3.282	66	Weighted Average
3.282	66	100.00% Pervious Area

Tc (min)	Length (feet)	Slope (ft/ft)	Velocity (ft/sec)	Capacity (cfs)	Description
8.9	100	0.0200	0.19		Sheet Flow, Grass: Short n= 0.150 P2= 3.88"
2.5	328	0.0180	2.16		Shallow Concentrated Flow, Unpaved Kv= 16.1 fps
11.4	428				Total

**Subcatchment 3S: E-1 Pervious**

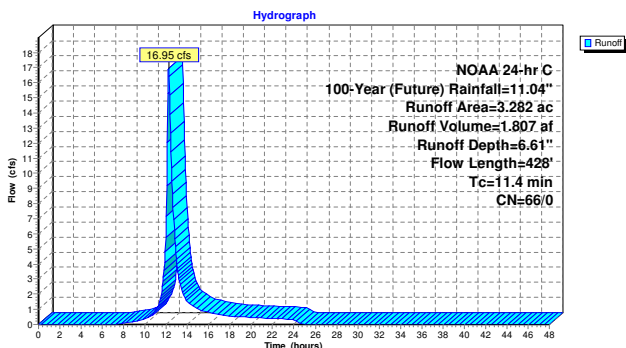

**Summary for Subcatchment 4S: E-2 Pervious**

Runoff = 1.70 cfs @ 12.10 hrs, Volume= 0.108 af, Depth= 5.90"  
 Routed to Link 7L : POA #2

Runoff by SCS TR-20 method, UH=Delmarva, Split Pervious/Imperv., Time Span= 0.00-48.00 hrs, dt= 0.05 hrs  
 NOAA 24-hr C 100-Year (Future) Rainfall=11.04"

Area (ac)	CN	Description
0.219	61	>75% Grass cover, Good, HSG B
0.219	61	100.00% Pervious Area

Tc (min)	Length (feet)	Slope (ft/ft)	Velocity (ft/sec)	Capacity (cfs)	Description
2.5	43	0.0900	0.29		Sheet Flow, Grass: Short n= 0.150 P2= 3.88"

**Subcatchment 4S: E-2 Pervious**

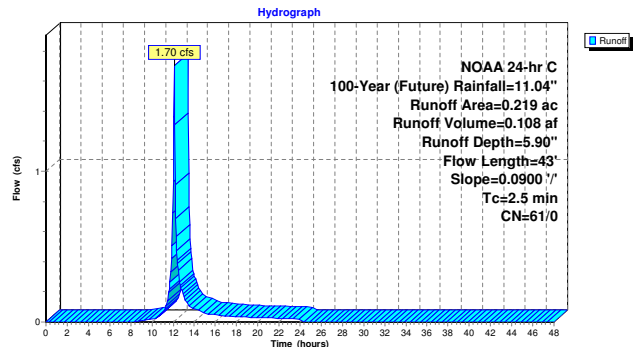

**Existing Conditions-Future**

NOAA 24-hr C 100-Year (Future) Rainfall=11.04"

Prepared by Taylor, Wiseman, Taylor  
HydroCAD® 10.20-2h s/n 04583 © 2024 HydroCAD Software Solutions LLC  
Printed 8/27/2025 Page 21

**Summary for Link 6L: POA #1**

Inflow Area = 8.468 ac, 61.24% Impervious, Inflow Depth = 9.17" for 100-Year (Future) event  
Inflow = 66.96 cfs @ 12.13 hrs, Volume= 6.474 af  
Primary = 66.96 cfs @ 12.13 hrs, Volume= 6.474 af, Atten= 0%, Lag= 0.0 min  
Routed to nonexistent node 9L

Primary outflow = Inflow, Time Span= 0.00-48.00 hrs, dt= 0.05 hrs

**Link 6L: POA #1**

Hydrograph

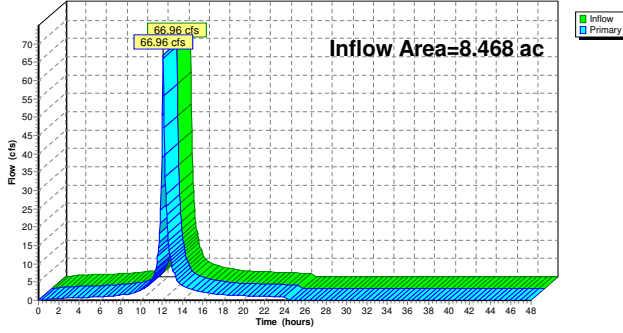

**Existing Conditions-Future**

NOAA 24-hr C 100-Year (Future) Rainfall=11.04"

Prepared by Taylor, Wiseman, Taylor  
HydroCAD® 10.20-2h s/n 04583 © 2024 HydroCAD Software Solutions LLC  
Printed 8/27/2025 Page 22

**Summary for Link 7L: POA #2**

Inflow Area = 0.641 ac, 65.83% Impervious, Inflow Depth = 9.12" for 100-Year (Future) event  
Inflow = 6.66 cfs @ 12.10 hrs, Volume= 0.487 af  
Primary = 6.66 cfs @ 12.10 hrs, Volume= 0.487 af, Atten= 0%, Lag= 0.0 min  
Routed to nonexistent node 9L

Primary outflow = Inflow, Time Span= 0.00-48.00 hrs, dt= 0.05 hrs

**Link 7L: POA #2**

Hydrograph

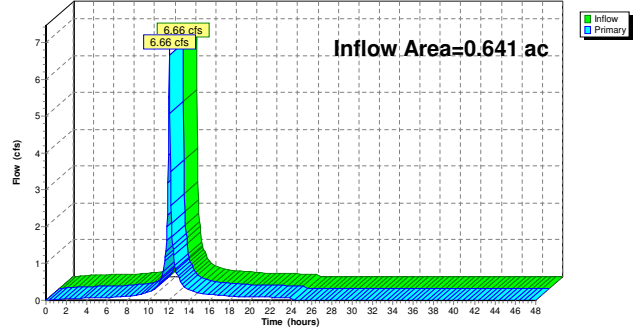

## **APPENDIX C: POST-CONSTRUCTION STORM ROUTINGS**



**Proposed Conditions-Current\_Rev1**

NOAA 24-hr C 2-Year (Current) Rainfall=3.29"

Prepared by Taylor, Wiseman, Taylor Printed 8/27/2025  
HydroCAD® 10.20-2h s/n 04583 © 2024 HydroCAD Software Solutions LLC Page 2

Time span=0.00-48.00 hrs, dt=0.05 hrs, 961 points  
Runoff by SCS TR-20 method, UH=Delmarva, Split Pervious/Imperv.  
Reach routing by Stor-Ind+Trans method - Pond routing by Stor-Ind method

- Subcatchment 1S: P-1B Impervious** Runoff Area=5.072 ac 100.00% Impervious Runoff Depth=3.06"  
Flow Length=528' Tc=4.4 min CN=0/98 Runoff=15.36 cfs 1.292 af
- Subcatchment 2S: P-2 Impervious** Runoff Area=0.283 ac 100.00% Impervious Runoff Depth=3.06"  
Flow Length=237' Slope=0.0100 1' Tc=2.7 min CN=0/98 Runoff=0.97 cfs 0.072 af
- Subcatchment 3S: P-1B Pervious** Runoff Area=3.053 ac 0.00% Impervious Runoff Depth=0.69"  
Flow Length=428' Tc=12.2 min CN=66/0 Runoff=1.26 cfs 0.175 af
- Subcatchment 4S: P-2 Pervious** Runoff Area=0.263 ac 0.00% Impervious Runoff Depth=0.48"  
Flow Length=43' Slope=0.0900 1' Tc=2.7 min CN=61/0 Runoff=0.12 cfs 0.011 af
- Subcatchment 11S: P-1A Impervious** Runoff Area=0.443 ac 100.00% Impervious Runoff Depth=3.06"  
Tc=5.0 min CN=0/98 Runoff=1.30 cfs 0.113 af

- Pond 8P: StormTech** Peak Elev=91.34' Storage=0.063 af Inflow=1.30 cfs 0.113 af  
Discarded=0.05 cfs 0.113 af Primary=0.00 cfs 0.000 af Outflow=0.05 cfs 0.113 af
- Link 6L: POA #1** Inflow=16.09 cfs 1.467 af  
Primary=16.09 cfs 1.467 af
- Link 7L: POA #2** Inflow=1.09 cfs 0.083 af  
Primary=1.09 cfs 0.083 af

**Total Runoff Area = 9.114 ac Runoff Volume = 1.663 af Average Runoff Depth = 2.19"**  
36.38% Pervious = 3.316 ac 63.62% Impervious = 5.798 ac

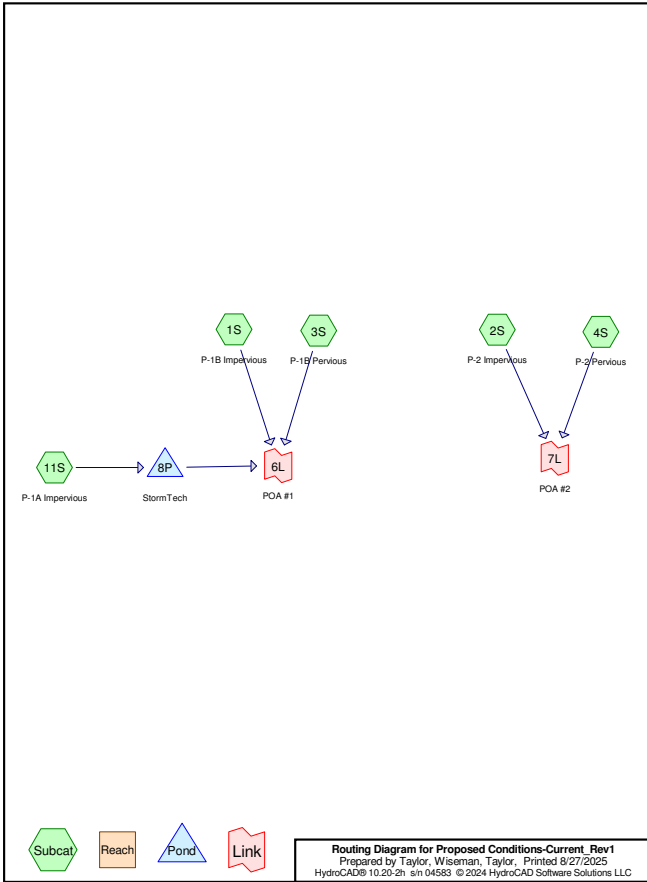

**Proposed Conditions-Current\_Rev1**

NOAA 24-hr C 2-Year (Current) Rainfall=3.29"

Prepared by Taylor, Wiseman, Taylor Printed 8/27/2025  
HydroCAD® 10.20-2h s/n 04583 © 2024 HydroCAD Software Solutions LLC Page 3

**Summary for Subcatchment 1S: P-1B Impervious**

Runoff = 15.36 cfs @ 12.12 hrs, Volume= 1.292 af, Depth= 3.06"  
Routed to Link 6L : POA #1

Runoff by SCS TR-20 method, UH=Delmarva, Split Pervious/Imperv., Time Span= 0.00-48.00 hrs, dt= 0.05 hrs  
NOAA 24-hr C 2-Year (Current) Rainfall=3.29"

Area (ac)	CN	Description			
5.072	98	100.00% Impervious Area			
Tc	Length (feet)	Slope (ft/ft)	Velocity (ft/sec)	Capacity (cfs)	Description
1.6	100	0.0100	1.06		Sheet Flow, Smooth surfaces n= 0.011 P2= 3.29"
2.8	428	0.0160	2.57		Shallow Concentrated Flow, Paved Kv= 20.3 fps
4.4	528	Total			

**Subcatchment 1S: P-1B Impervious**

Hydrograph

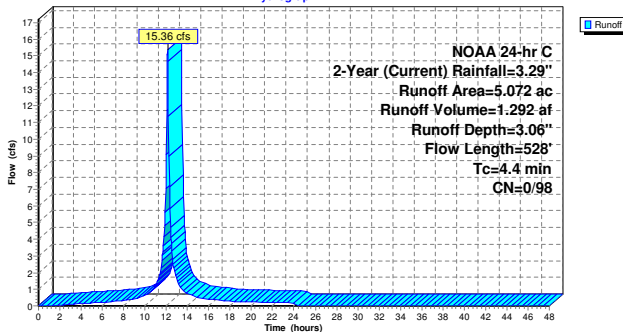

**Proposed Conditions-Current\_Rev1**

NOAA 24-hr C 2-Year (Current) Rainfall=3.29"

Prepared by Taylor, Wiseman, Taylor Printed 8/27/2025  
HydroCAD® 10.20-2h s/n 04583 © 2024 HydroCAD Software Solutions LLC Page 4

**Summary for Subcatchment 2S: P-2 Impervious**

Runoff = 0.97 cfs @ 12.10 hrs, Volume= 0.072 af, Depth= 3.06"  
Routed to Link 7L : POA #2

Runoff by SCS TR-20 method, UH=Delmarva, Split Pervious/Imperv., Time Span= 0.00-48.00 hrs, dt= 0.05 hrs  
NOAA 24-hr C 2-Year (Current) Rainfall=3.29"

Area (ac)	CN	Description			
0.283	98	100.00% Impervious Area			
Tc	Length (feet)	Slope (ft/ft)	Velocity (ft/sec)	Capacity (cfs)	Description
1.6	100	0.0100	1.06		Sheet Flow, Smooth surfaces n= 0.011 P2= 3.29"
1.1	137	0.0100	2.03		Shallow Concentrated Flow, Paved Kv= 20.3 fps
2.7	237	Total			

**Subcatchment 2S: P-2 Impervious**

Hydrograph

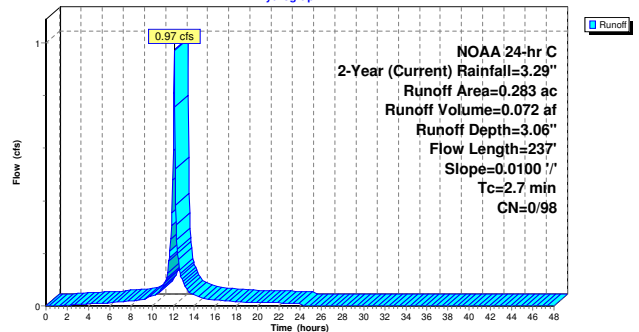

**Summary for Subcatchment 3S: P-1B Pervious**

Runoff = 1.26 cfs @ 12.27 hrs, Volume= 0.175 af, Depth= 0.69"  
 Routed to Link 6L : POA #1

Runoff by SCS TR-20 method, UH=Delmarva, Split Pervious/Imperv., Time Span= 0.00-48.00 hrs, dt= 0.05 hrs  
 NOAA 24-hr C 2-Year (Current) Rainfall=3.29"

Area (ac)	CN	Description
1.849	61	>75% Grass cover, Good, HSG B
1.204	74	>75% Grass cover, Good, HSG C
3.053	66	Weighted Average
3.053	66	100.00% Pervious Area

Tc (min)	Length (feet)	Slope (ft/ft)	Velocity (ft/sec)	Capacity (cfs)	Description
9.7	100	0.0200	0.17		Sheet Flow, Grass: Short n= 0.150 P2= 3.29"
2.5	328	0.0180	2.16		Shallow Concentrated Flow, Unpaved Kv= 16.1 fps
12.2	428				Total

**Subcatchment 3S: P-1B Pervious**

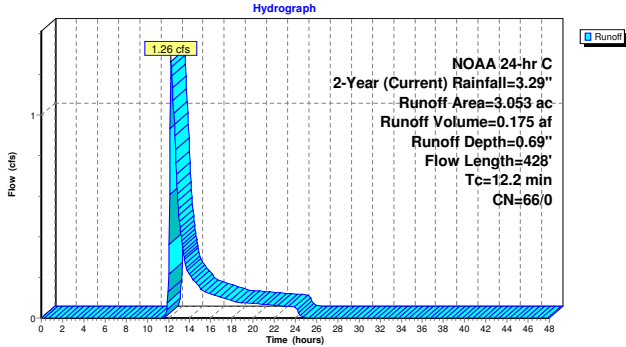

**Summary for Subcatchment 4S: P-2 Pervious**

Runoff = 0.12 cfs @ 12.12 hrs, Volume= 0.011 af, Depth= 0.48"  
 Routed to Link 7L : POA #2

Runoff by SCS TR-20 method, UH=Delmarva, Split Pervious/Imperv., Time Span= 0.00-48.00 hrs, dt= 0.05 hrs  
 NOAA 24-hr C 2-Year (Current) Rainfall=3.29"

Area (ac)	CN	Description
0.263	61	>75% Grass cover, Good, HSG B
0.263	61	100.00% Pervious Area

Tc (min)	Length (feet)	Slope (ft/ft)	Velocity (ft/sec)	Capacity (cfs)	Description
2.7	43	0.0900	0.27		Sheet Flow, Grass: Short n= 0.150 P2= 3.29"

**Subcatchment 4S: P-2 Pervious**

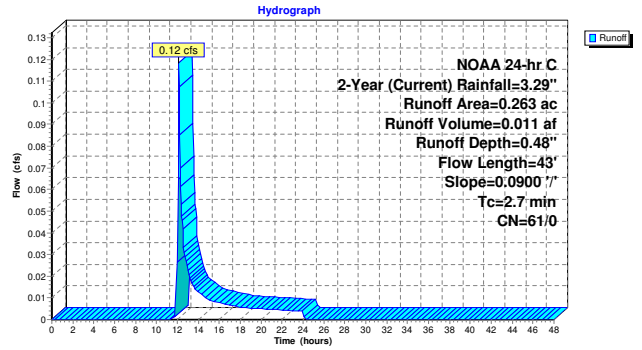

**Summary for Subcatchment 11S: P-1A Impervious**

Runoff = 1.30 cfs @ 12.13 hrs, Volume= 0.113 af, Depth= 3.06"  
 Routed to Pond 8P : StormTech

Runoff by SCS TR-20 method, UH=Delmarva, Split Pervious/Imperv., Time Span= 0.00-48.00 hrs, dt= 0.05 hrs  
 NOAA 24-hr C 2-Year (Current) Rainfall=3.29"

Area (ac)	CN	Description
0.443	98	
0.443	98	100.00% Impervious Area

Tc (min)	Length (feet)	Slope (ft/ft)	Velocity (ft/sec)	Capacity (cfs)	Description
5.0					Direct Entry, roof

**Subcatchment 11S: P-1A Impervious**

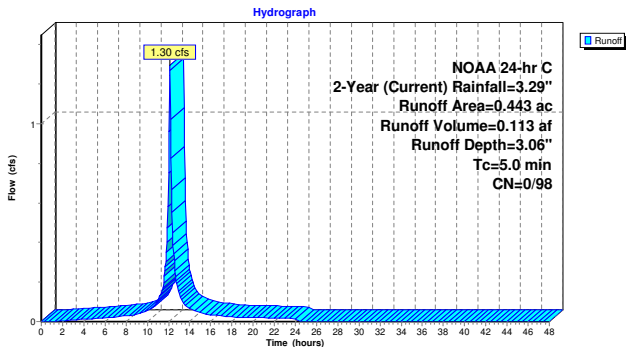

**Summary for Pond 8P: StormTech**

Inflow Area = 0.443 ac, 100.00% Impervious, Inflow Depth = 3.06" for 2-Year (Current) event  
 Inflow = 1.30 cfs @ 12.13 hrs, Volume= 0.113 af  
 Outflow = 0.05 cfs @ 14.92 hrs, Volume= 0.113 af, Atten= 96%, Lag= 167.1 min  
 Discarded = 0.05 cfs @ 14.92 hrs, Volume= 0.113 af  
 Primary = 0.00 cfs @ 0.00 hrs, Volume= 0.000 af  
 Routed to Link 6L : POA #1

Routing by Stor-Ind method, Time Span= 0.00-48.00 hrs, dt= 0.05 hrs  
 Peak Elev= 91.34' @ 14.92 hrs Surf.Area= 0.081 ac Storage= 0.063 af

Plug-Flow detention time= 532.8 min calculated for 0.113 af (100% of inflow)  
 Center-of-Mass det. time= 533.1 min ( 1,292.2 - 759.1 )

Volume	Invert	Avail. Storage	Storage Description
#1A	90.00'	0.080 af	39.50'W x 89.06'L x 3.75'H Field A 0.303 af Overall - 0.102 af Embedded = 0.201 af x 40.0% Voids
#2A	90.75'	0.102 af	ADS StormTech DC-780 +Cap x 96 Inside #1 Effective Size= 45.4"W x 30.0"H => 6.49 sf x 7.12'L = 46.2 cf Overall Size= 51.0"W x 30.0"H x 7.56'L with 0.44' Overlap 96 Chambers in 8 Rows
		0.182 af	Total Available Storage

Storage Group A created with Chamber Wizard

Device	Routing	Invert	Outlet Devices
#1	Discarded	90.00'	0.500 in/hr Exfiltration over Surface area Conductivity to Groundwater Elevation = 81.00'
#2	Primary	92.15'	6.0" W x 12.0" H Vert. Orifice1 C= 0.600 Limited to weir flow at low heads
#3	Primary	93.42'	48.0" W x 4.0" H Vert. Orifice #2 C= 0.600 Limited to weir flow at low heads

Discarded OutFlow Max=0.05 cfs @ 14.92 hrs HW=91.34' (Free Discharge)  
 1=Exfiltration ( Controls 0.05 cfs)

Primary OutFlow Max=0.00 cfs @ 0.00 hrs HW=90.00' (Free Discharge)  
 2=Orifice1 ( Controls 0.00 cfs)  
 3=Orifice #2 ( Controls 0.00 cfs)

**Pond 8P: StormTech - Chamber Wizard Field A**

Chamber Model = ADS\_StormTech DC-780 +Cap (ADS StormTech® DC-780 with cap length)  
 Effective Size= 45.4"W x 30.0"H => 6.49 sf x 7.12'L = 46.2 cf  
 Overall Size= 51.0"W x 30.0"H x 7.56'L with 0.44' Overlap  
 51.0" Wide + 6.0" Spacing = 57.0" C-C Row Spacing  
 12 Chambers/Row x 7.12' Long +0.81' Cap Length x 2 = 87.06' Row Length +12.0" End Stone x 2 = 89.06' Base Length  
 8 Rows x 51.0" Wide + 6.0" Spacing x 7 + 12.0" Side Stone x 2 = 39.50' Base Width  
 9.0" Stone Base + 30.0" Chamber Height + 6.0" Stone Cover = 3.75' Field Height  
 96 Chambers x 46.2 cf = 4,438.9 cf Chamber Storage  
 13,191.5 cf Field - 4,438.9 cf Chambers = 8,752.6 cf Stone x 40.0% Voids = 3,501.0 cf Stone Storage  
 Chamber Storage + Stone Storage = 7,940.0 cf = 0.182 af  
 Overall Storage Efficiency = 60.2%  
 Overall System Size = 89.06' x 39.50' x 3.75'

96 Chambers  
 488.6 cy Field  
 324.2 cy Stone

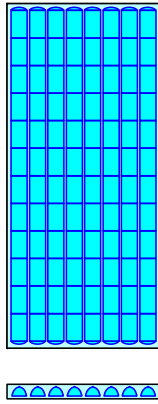

**Pond 8P: StormTech**

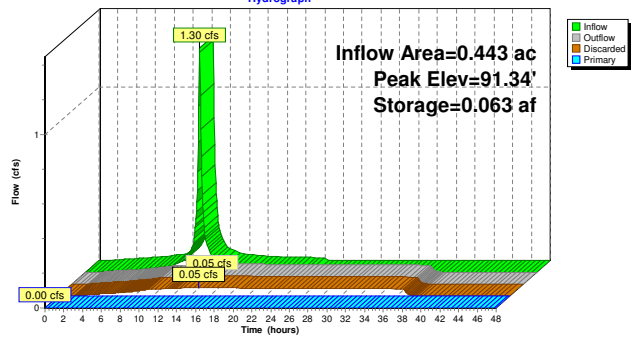

**Pond 8P: StormTech**

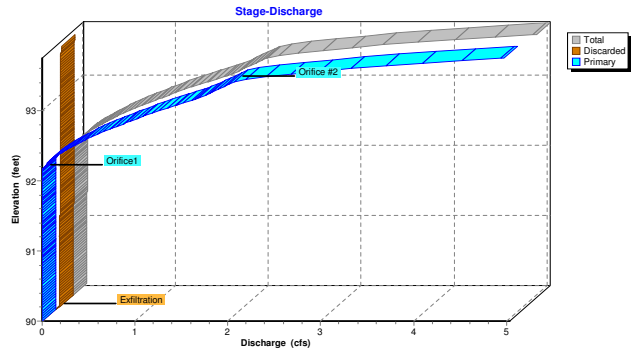

**Pond 8P: StormTech**

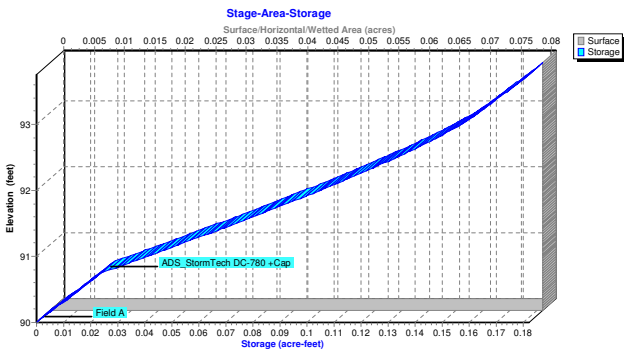

**Summary for Link 6L: POA #1**

Inflow Area = 8.568 ac, 64.37% Impervious, Inflow Depth = 2.06" for 2-Year (Current) event  
 Inflow = 16.09 cfs @ 12.12 hrs, Volume= 1.467 af  
 Primary = 16.09 cfs @ 12.12 hrs, Volume= 1.467 af, Atten= 0%, Lag= 0.0 min  
 Routed to nonexistent node 9L

Primary outflow = Inflow, Time Span= 0.00-48.00 hrs, dt= 0.05 hrs

**Link 6L: POA #1**

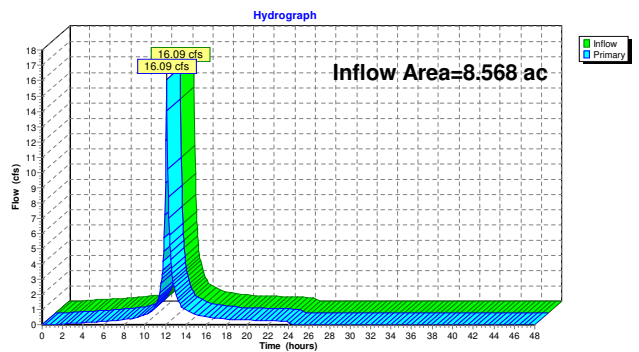

Summary for Link 7L: POA #2

Inflow Area = 0.546 ac, 51.83% Impervious, Inflow Depth = 1.82" for 2-Year (Current) event  
 Inflow = 1.09 cfs @ 12.10 hrs, Volume= 0.083 af  
 Primary = 1.09 cfs @ 12.10 hrs, Volume= 0.083 af, Atten= 0%, Lag= 0.0 min  
 Routed to nonexistent node 9L

Primary outflow = Inflow, Time Span= 0.00-48.00 hrs, dt= 0.05 hrs

Link 7L: POA #2

Hydrograph

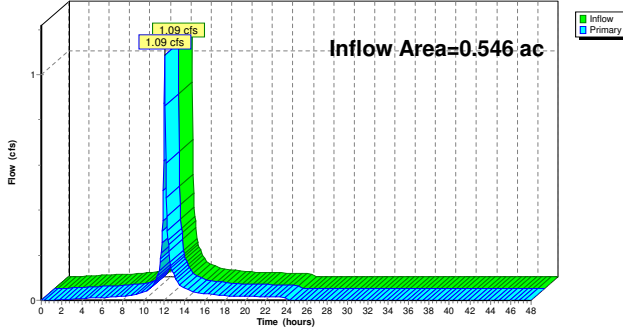

Time span=0.00-48.00 hrs, dt=0.05 hrs, 961 points  
 Runoff by SCS TR-20 method, UH=Delmarva, Split Pervious/Imperv.  
 Reach routing by Stor-Ind+Trans method - Pond routing by Stor-Ind method

- Subcatchment 1S: P-1B Impervious** Runoff Area=5.072 ac 100.00% Impervious Runoff Depth=4.85"  
 Flow Length=528' Tc=4.4 min CN=0/98 Runoff=23.93 cfs 2.051 af
  - Subcatchment 2S: P-2 Impervious** Runoff Area=0.283 ac 100.00% Impervious Runoff Depth=4.85"  
 Flow Length=237' Slope=0.0100 1' Tc=2.7 min CN=0/98 Runoff=1.52 cfs 0.114 af
  - Subcatchment 3S: P-1B Pervious** Runoff Area=3.053 ac 0.00% Impervious Runoff Depth=1.79"  
 Flow Length=428' Tc=12.2 min CN=66/0 Runoff=3.89 cfs 0.455 af
  - Subcatchment 4S: P-2 Pervious** Runoff Area=0.263 ac 0.00% Impervious Runoff Depth=1.42"  
 Flow Length=43' Slope=0.0900 1' Tc=2.7 min CN=61/0 Runoff=0.46 cfs 0.031 af
  - Subcatchment 11S: P-1A Impervious** Runoff Area=0.443 ac 100.00% Impervious Runoff Depth=4.85"  
 Tc=5.0 min CN=0/98 Runoff=2.02 cfs 0.179 af
  - Pond 8P: StormTech** Peak Elev=92.13' Storage=0.113 af Inflow=2.02 cfs 0.179 af  
 Discarded=0.05 cfs 0.168 af Primary=0.00 cfs 0.000 af Outflow=0.05 cfs 0.168 af
  - Link 6L: POA #1** Inflow=26.57 cfs 2.506 af  
 Primary=26.57 cfs 2.506 af
  - Link 7L: POA #2** Inflow=1.97 cfs 0.146 af  
 Primary=1.97 cfs 0.146 af
- Total Runoff Area = 9.114 ac Runoff Volume = 2.831 af Average Runoff Depth = 3.73"**  
**36.38% Pervious = 3.316 ac 63.62% Impervious = 5.798 ac**

Summary for Subcatchment 1S: P-1B Impervious

Runoff = 23.93 cfs @ 12.12 hrs, Volume= 2.051 af, Depth= 4.85"  
 Routed to Link 6L: POA #1

Runoff by SCS TR-20 method, UH=Delmarva, Split Pervious/Imperv., Time Span= 0.00-48.00 hrs, dt= 0.05 hrs  
 NOAA 24-hr C 10-Year (Current) Rainfall=5.09"

Area (ac)	CN	Description
5.072	98	
5.072	98	100.00% Impervious Area

Tc (min)	Length (feet)	Slope (ft/ft)	Velocity (ft/sec)	Capacity (cfs)	Description
1.6	100	0.0100	1.06		Sheet Flow, Smooth surfaces n= 0.011 P2= 3.29"
2.8	428	0.0160	2.57		Shallow Concentrated Flow, Paved Kv= 20.3 fps
4.4	528	Total			

Subcatchment 1S: P-1B Impervious

Hydrograph

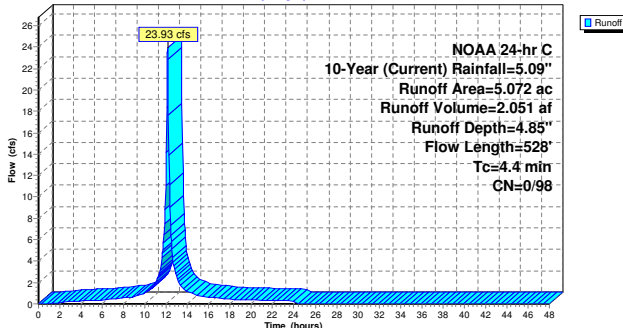

Summary for Subcatchment 2S: P-2 Impervious

Runoff = 1.52 cfs @ 12.10 hrs, Volume= 0.114 af, Depth= 4.85"  
 Routed to Link 7L: POA #2

Runoff by SCS TR-20 method, UH=Delmarva, Split Pervious/Imperv., Time Span= 0.00-48.00 hrs, dt= 0.05 hrs  
 NOAA 24-hr C 10-Year (Current) Rainfall=5.09"

Area (ac)	CN	Description
0.283	98	
0.283	98	100.00% Impervious Area

Tc (min)	Length (feet)	Slope (ft/ft)	Velocity (ft/sec)	Capacity (cfs)	Description
1.6	100	0.0100	1.06		Sheet Flow, Smooth surfaces n= 0.011 P2= 3.29"
1.1	137	0.0100	2.03		Shallow Concentrated Flow, Paved Kv= 20.3 fps
2.7	237	Total			

Subcatchment 2S: P-2 Impervious

Hydrograph

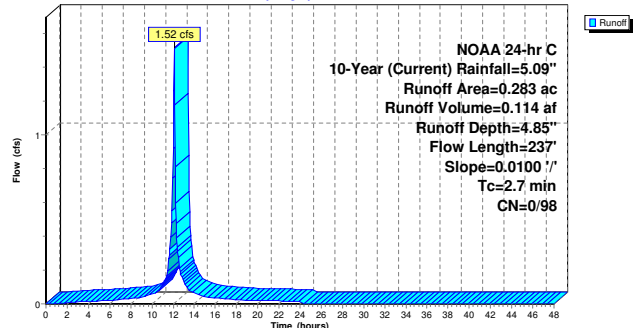

**Summary for Subcatchment 3S: P-1B Pervious**

Runoff = 3.89 cfs @ 12.24 hrs, Volume= 0.455 af, Depth= 1.79"  
 Routed to Link 6L : POA #1

Runoff by SCS TR-20 method, UH=Delmarva, Split Pervious/Imperv., Time Span= 0.00-48.00 hrs, dt= 0.05 hrs  
 NOAA 24-hr C 10-Year (Current) Rainfall=5.09"

Area (ac)	CN	Description
1.849	61	>75% Grass cover, Good, HSG B
1.204	74	>75% Grass cover, Good, HSG C
3.053	66	Weighted Average
3.053	66	100.00% Pervious Area

Tc (min)	Length (feet)	Slope (ft/ft)	Velocity (ft/sec)	Capacity (cfs)	Description
9.7	100	0.0200	0.17		Sheet Flow, Grass: Short n= 0.150 P2= 3.29"
2.5	328	0.0180	2.16		Shallow Concentrated Flow, Unpaved Kv= 16.1 fps
12.2	428				Total

**Subcatchment 3S: P-1B Pervious**

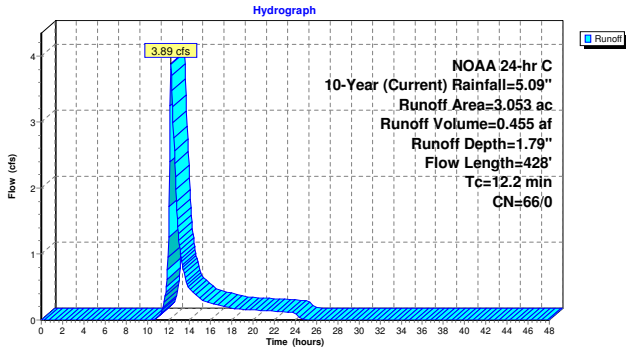

**Summary for Subcatchment 4S: P-2 Pervious**

Runoff = 0.46 cfs @ 12.11 hrs, Volume= 0.031 af, Depth= 1.42"  
 Routed to Link 7L : POA #2

Runoff by SCS TR-20 method, UH=Delmarva, Split Pervious/Imperv., Time Span= 0.00-48.00 hrs, dt= 0.05 hrs  
 NOAA 24-hr C 10-Year (Current) Rainfall=5.09"

Area (ac)	CN	Description
0.263	61	>75% Grass cover, Good, HSG B
0.263	61	100.00% Pervious Area

Tc (min)	Length (feet)	Slope (ft/ft)	Velocity (ft/sec)	Capacity (cfs)	Description
2.7	43	0.0900	0.27		Sheet Flow, Grass: Short n= 0.150 P2= 3.29"

**Subcatchment 4S: P-2 Pervious**

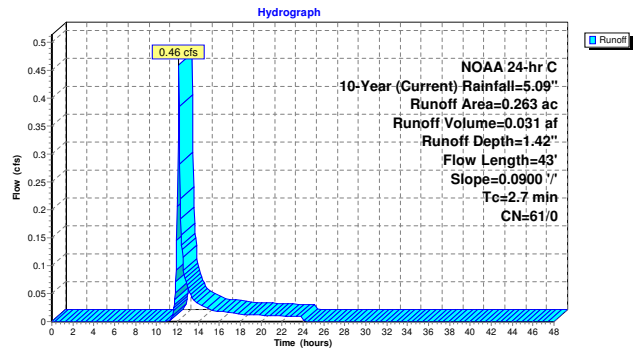

**Summary for Subcatchment 11S: P-1A Impervious**

Runoff = 2.02 cfs @ 12.13 hrs, Volume= 0.179 af, Depth= 4.85"  
 Routed to Pond 8P : StormTech

Runoff by SCS TR-20 method, UH=Delmarva, Split Pervious/Imperv., Time Span= 0.00-48.00 hrs, dt= 0.05 hrs  
 NOAA 24-hr C 10-Year (Current) Rainfall=5.09"

Area (ac)	CN	Description
0.443	98	
0.443	98	100.00% Impervious Area

Tc (min)	Length (feet)	Slope (ft/ft)	Velocity (ft/sec)	Capacity (cfs)	Description
5.0					Direct Entry, roof

**Subcatchment 11S: P-1A Impervious**

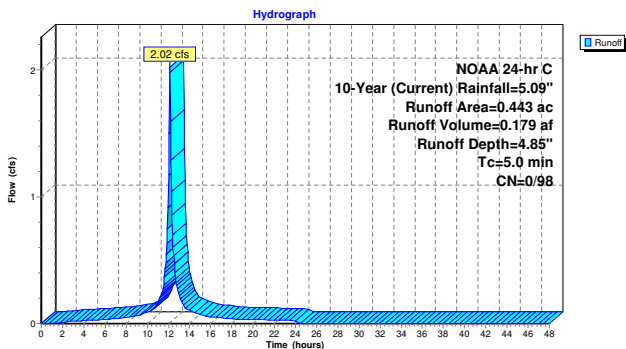

**Summary for Pond 8P: StormTech**

Inflow Area = 0.443 ac, 100.00% Impervious, Inflow Depth = 4.85" for 10-Year (Current) event  
 Inflow = 2.02 cfs @ 12.13 hrs, Volume= 0.179 af  
 Outflow = 0.05 cfs @ 16.65 hrs, Volume= 0.168 af, Atten= 98%, Lag= 271.3 min  
 Discarded = 0.05 cfs @ 16.65 hrs, Volume= 0.168 af  
 Primary = 0.00 cfs @ 0.00 hrs, Volume= 0.000 af  
 Routed to Link 6L : POA #1

Routing by Stor-Ind method, Time Span= 0.00-48.00 hrs, dt= 0.05 hrs  
 Peak Elev= 92.13' @ 16.65 hrs Surf.Area= 0.081 ac Storage= 0.113 af

Plug-Flow detention time= 844.4 min calculated for 0.168 af (94% of inflow)  
 Center-of-Mass det. time= 809.2 min ( 1,559.8 - 750.7 )

Volume	Invert	Avail.Storage	Storage Description
#1A	90.00'	0.080 af	39.50'W x 89.06'L x 3.75'H Field A 0.303 af Overall - 0.102 af Embedded = 0.201 af x 40.0% Voids
#2A	90.75'	0.102 af	ADS StormTech DC-780 +Cap x 96 Inside #1 Effective Size= 45.4"W x 30.0"H => 6.49 sf x 7.12'L = 46.2 cf Overall Size= 51.0"W x 30.0"H x 7.56'L with 0.44' Overlap 96 Chambers in 8 Rows
		0.182 af	Total Available Storage

Storage Group A created with Chamber Wizard

Device	Routing	Invert	Outlet Devices
#1	Discarded	90.00'	0.500 in/hr Exfiltration over Surface area Conductivity to Groundwater Elevation = 81.00'
#2	Primary	92.15'	6.0" W x 12.0" H Vert. Orifice1 C= 0.600 Limited to weir flow at low heads
#3	Primary	93.42'	48.0" W x 4.0" H Vert. Orifice #2 C= 0.600 Limited to weir flow at low heads

Discarded OutFlow Max=0.05 cfs @ 16.65 hrs HW=92.13' (Free Discharge)  
 1=Exfiltration ( Controls 0.05 cfs)

Primary OutFlow Max=0.00 cfs @ 0.00 hrs HW=90.00' (Free Discharge)  
 2=Orifice1 ( Controls 0.00 cfs)  
 3=Orifice #2 ( Controls 0.00 cfs)

**Pond 8P: StormTech - Chamber Wizard Field A**

Chamber Model = ADS\_StormTech DC-780 +Cap (ADS StormTech® DC-780 with cap length)  
 Effective Size= 45.4"W x 30.0"H => 6.49 sf x 7.12'L = 46.2 cf  
 Overall Size= 51.0"W x 30.0"H x 7.56'L with 0.44' Overlap  
 51.0" Wide + 6.0" Spacing = 57.0" C-C Row Spacing  
 12 Chambers/Row x 7.12' Long +0.81' Cap Length x 2 = 87.06' Row Length +12.0" End Stone x 2 = 89.06' Base Length  
 8 Rows x 51.0" Wide + 6.0" Spacing x 7 + 12.0" Side Stone x 2 = 39.50' Base Width  
 9.0" Stone Base + 30.0" Chamber Height + 6.0" Stone Cover = 3.75' Field Height  
 96 Chambers x 46.2 cf = 4,438.9 cf Chamber Storage  
 13,191.5 cf Field - 4,438.9 cf Chambers = 8,752.6 cf Stone x 40.0% Voids = 3,501.0 cf Stone Storage  
 Chamber Storage + Stone Storage = 7,940.0 cf = 0.182 af  
 Overall Storage Efficiency = 60.2%  
 Overall System Size = 89.06' x 39.50' x 3.75'

96 Chambers  
 488.6 cy Field  
 324.2 cy Stone

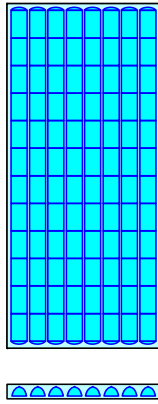

**Pond 8P: StormTech**

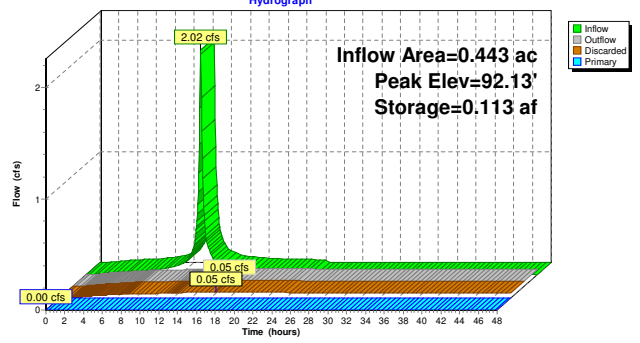

**Pond 8P: StormTech**

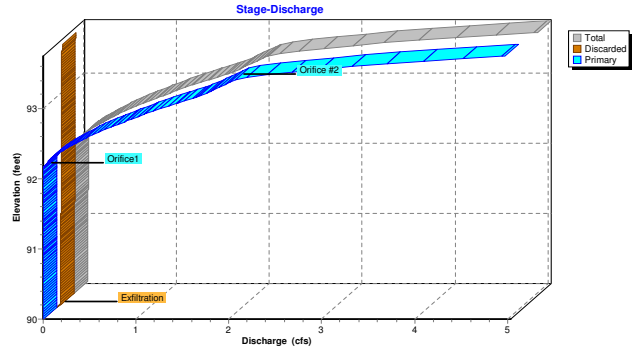

**Pond 8P: StormTech**

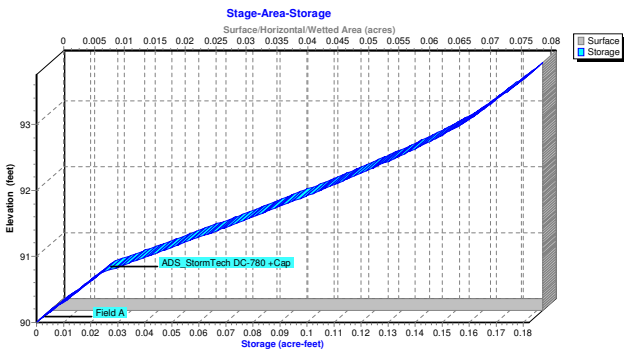

**Summary for Link 6L: POA #1**

Inflow Area = 8.568 ac, 64.37% Impervious, Inflow Depth = 3.51" for 10-Year (Current) event  
 Inflow = 26.57 cfs @ 12.13 hrs, Volume= 2.506 af  
 Primary = 26.57 cfs @ 12.13 hrs, Volume= 2.506 af, Atten= 0%, Lag= 0.0 min  
 Routed to nonexistent node 9L  
 Primary outflow = Inflow, Time Span= 0.00-48.00 hrs, dt= 0.05 hrs

**Link 6L: POA #1**

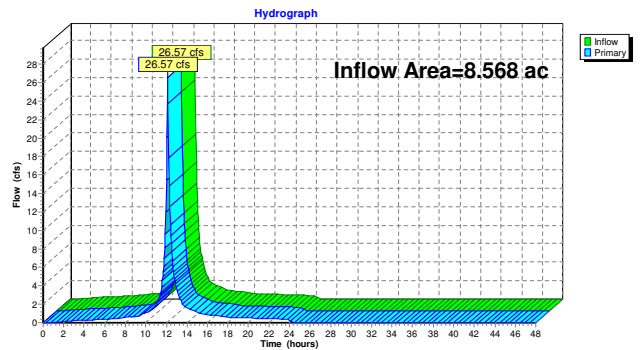

Summary for Link 7L: POA #2

Inflow Area = 0.546 ac, 51.83% Impervious, Inflow Depth = 3.20" for 10-Year (Current) event  
 Inflow = 1.97 cfs @ 12.10 hrs, Volume= 0.146 af  
 Primary = 1.97 cfs @ 12.10 hrs, Volume= 0.146 af, Atten= 0%, Lag= 0.0 min  
 Routed to nonexistent node 9L

Primary outflow = Inflow, Time Span= 0.00-48.00 hrs, dt= 0.05 hrs

Link 7L: POA #2

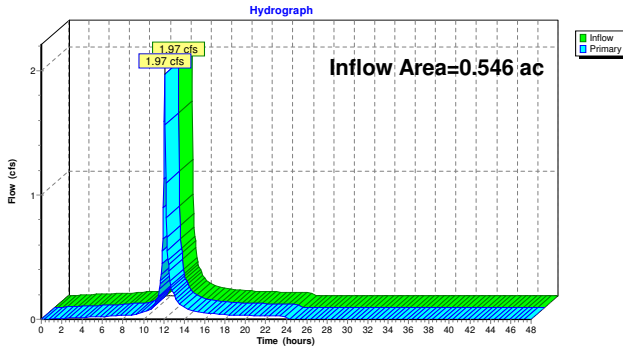

Time span=0.00-48.00 hrs, dt=0.05 hrs, 961 points  
 Runoff by SCS TR-20 method, UH=Delmarva, Split Pervious/Imperv.  
 Reach routing by Stor-Ind+Trans method - Pond routing by Stor-Ind method

- Subcatchment 1S: P-1B Impervious** Runoff Area=5.072 ac 100.00% Impervious Runoff Depth=8.45"  
 Flow Length=528' Tc=4.4 min CN=0/98 Runoff=41.00 cfs 3.571 af
  - Subcatchment 2S: P-2 Impervious** Runoff Area=0.283 ac 100.00% Impervious Runoff Depth=8.45"  
 Flow Length=237' Slope=0.0100 1/ Tc=2.7 min CN=0/98 Runoff=2.60 cfs 0.199 af
  - Subcatchment 3S: P-1B Pervious** Runoff Area=3.053 ac 0.00% Impervious Runoff Depth=4.58"  
 Flow Length=428' Tc=12.2 min CN=66/0 Runoff=10.54 cfs 1.165 af
  - Subcatchment 4S: P-2 Pervious** Runoff Area=0.263 ac 0.00% Impervious Runoff Depth=3.98"  
 Flow Length=43' Slope=0.0900 1/ Tc=2.7 min CN=61/0 Runoff=1.35 cfs 0.087 af
  - Subcatchment 11S: P-1A Impervious** Runoff Area=0.443 ac 100.00% Impervious Runoff Depth=8.45"  
 Tc=5.0 min CN=0/98 Runoff=3.46 cfs 0.312 af
  - Pond 8P: StormTech** Peak Elev=92.85' Storage=0.151 af Inflow=3.46 cfs 0.312 af  
 Discarded=0.05 cfs 0.179 af Primary=0.94 cfs 0.112 af Outflow=1.00 cfs 0.291 af
  - Link 6L: POA #1** Inflow=48.91 cfs 4.848 af  
 Primary=48.91 cfs 4.848 af
  - Link 7L: POA #2** Inflow=3.95 cfs 0.286 af  
 Primary=3.95 cfs 0.286 af
- Total Runoff Area = 9.114 ac Runoff Volume = 5.335 af Average Runoff Depth = 7.02"**  
**36.38% Pervious = 3.316 ac 63.62% Impervious = 5.798 ac**

Summary for Subcatchment 1S: P-1B Impervious

Runoff = 41.00 cfs @ 12.12 hrs, Volume= 3.571 af, Depth= 8.45"  
 Routed to Link 6L : POA #1

Runoff by SCS TR-20 method, UH=Delmarva, Split Pervious/Imperv., Time Span= 0.00-48.00 hrs, dt= 0.05 hrs  
 NOAA 24-hr C 100-Year (Current) Rainfall=8.69"

Area (ac)	CN	Description
5.072	98	
5.072	98	100.00% Impervious Area

Tc (min)	Length (feet)	Slope (ft/ft)	Velocity (ft/sec)	Capacity (cfs)	Description
1.6	100	0.0100	1.06		Sheet Flow, Smooth surfaces n= 0.011 P2= 3.29"
2.8	428	0.0160	2.57		Shallow Concentrated Flow, Paved Kv= 20.3 fps
4.4	528	Total			

Subcatchment 1S: P-1B Impervious

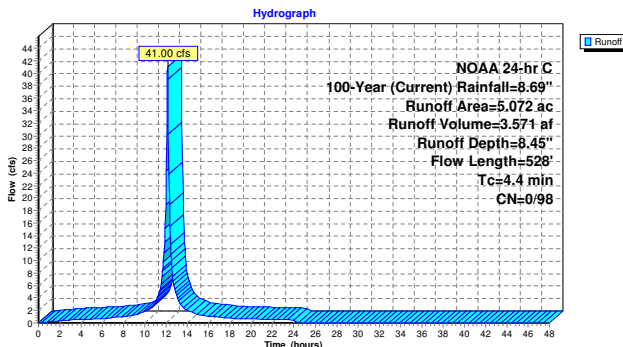

Summary for Subcatchment 2S: P-2 Impervious

Runoff = 2.60 cfs @ 12.10 hrs, Volume= 0.199 af, Depth= 8.45"  
 Routed to Link 7L : POA #2

Runoff by SCS TR-20 method, UH=Delmarva, Split Pervious/Imperv., Time Span= 0.00-48.00 hrs, dt= 0.05 hrs  
 NOAA 24-hr C 100-Year (Current) Rainfall=8.69"

Area (ac)	CN	Description
0.283	98	
0.283	98	100.00% Impervious Area

Tc (min)	Length (feet)	Slope (ft/ft)	Velocity (ft/sec)	Capacity (cfs)	Description
1.6	100	0.0100	1.06		Sheet Flow, Smooth surfaces n= 0.011 P2= 3.29"
1.1	137	0.0100	2.03		Shallow Concentrated Flow, Paved Kv= 20.3 fps
2.7	237	Total			

Subcatchment 2S: P-2 Impervious

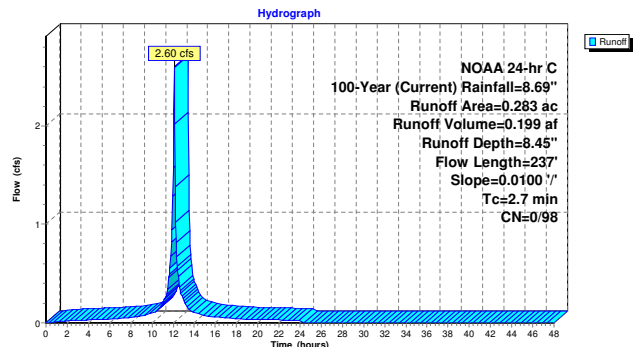

**Summary for Subcatchment 3S: P-1B Pervious**

Runoff = 10.54 cfs @ 12.22 hrs, Volume= 1.165 af, Depth= 4.58"  
 Routed to Link 6L : POA #1

Runoff by SCS TR-20 method, UH=Delmarva, Split Pervious/Imperv., Time Span= 0.00-48.00 hrs, dt= 0.05 hrs  
 NOAA 24-hr C 100-Year (Current) Rainfall=8.69"

Area (ac)	CN	Description
1.849	61	>75% Grass cover, Good, HSG B
1.204	74	>75% Grass cover, Good, HSG C
3.053	66	Weighted Average
3.053	66	100.00% Pervious Area

Tc (min)	Length (feet)	Slope (ft/ft)	Velocity (ft/sec)	Capacity (cfs)	Description
9.7	100	0.0200	0.17		Sheet Flow, Grass: Short n= 0.150 P2= 3.29"
2.5	328	0.0180	2.16		Shallow Concentrated Flow, Unpaved Kv= 16.1 fps
12.2	428				Total

**Subcatchment 3S: P-1B Pervious**

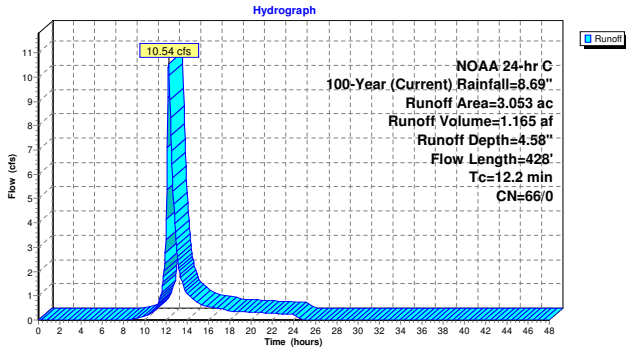

**Summary for Subcatchment 4S: P-2 Pervious**

Runoff = 1.35 cfs @ 12.10 hrs, Volume= 0.087 af, Depth= 3.98"  
 Routed to Link 7L : POA #2

Runoff by SCS TR-20 method, UH=Delmarva, Split Pervious/Imperv., Time Span= 0.00-48.00 hrs, dt= 0.05 hrs  
 NOAA 24-hr C 100-Year (Current) Rainfall=8.69"

Area (ac)	CN	Description
0.263	61	>75% Grass cover, Good, HSG B
0.263	61	100.00% Pervious Area

Tc (min)	Length (feet)	Slope (ft/ft)	Velocity (ft/sec)	Capacity (cfs)	Description
2.7	43	0.0900	0.27		Sheet Flow, Grass: Short n= 0.150 P2= 3.29"

**Subcatchment 4S: P-2 Pervious**

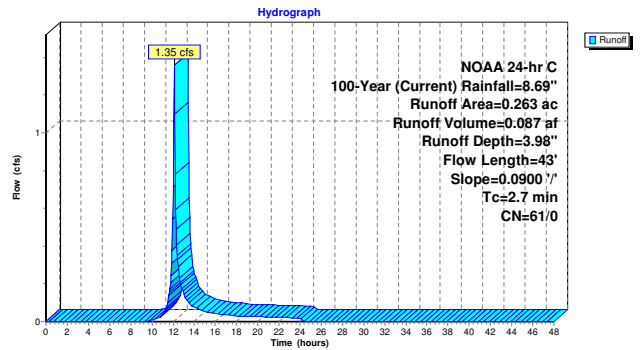

**Summary for Subcatchment 11S: P-1A Impervious**

Runoff = 3.46 cfs @ 12.13 hrs, Volume= 0.312 af, Depth= 8.45"  
 Routed to Pond 8P : StormTech

Runoff by SCS TR-20 method, UH=Delmarva, Split Pervious/Imperv., Time Span= 0.00-48.00 hrs, dt= 0.05 hrs  
 NOAA 24-hr C 100-Year (Current) Rainfall=8.69"

Area (ac)	CN	Description
0.443	98	
0.443	98	100.00% Impervious Area

Tc (min)	Length (feet)	Slope (ft/ft)	Velocity (ft/sec)	Capacity (cfs)	Description
5.0					Direct Entry, roof

**Subcatchment 11S: P-1A Impervious**

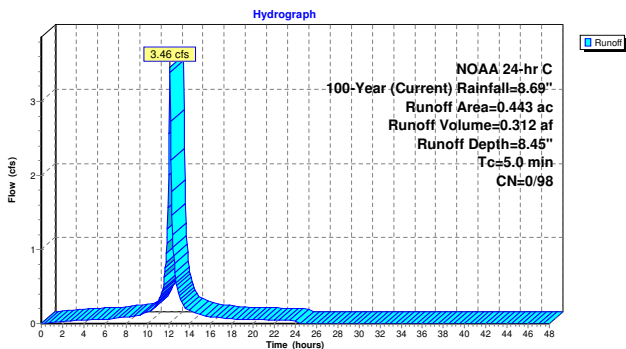

**Summary for Pond 8P: StormTech**

Inflow Area = 0.443 ac, 100.00% Impervious, Inflow Depth = 8.45" for 100-Year (Current) event  
 Inflow = 3.46 cfs @ 12.13 hrs, Volume= 0.312 af  
 Outflow = 1.00 cfs @ 12.47 hrs, Volume= 0.291 af, Atten= 71%, Lag= 20.3 min  
 Discarded = 0.05 cfs @ 12.47 hrs, Volume= 0.179 af  
 Primary = 0.94 cfs @ 12.47 hrs, Volume= 0.112 af  
 Routed to Link 6L : POA #1

Routing by Stor-Ind method, Time Span= 0.00-48.00 hrs, dt= 0.05 hrs  
 Peak Elev= 92.85' @ 12.47 hrs Surf.Area= 0.081 ac Storage= 0.151 af  
 Plug-Flow detention time= 539.1 min calculated for 0.291 af (93% of inflow)  
 Center-of-Mass det. time= 500.4 min ( 1,243.3 - 742.9 )

Volume	Invert	Avail.Storage	Storage Description
#1A	90.00'	0.080 af	39.50'W x 89.06'L x 3.75'H Field A 0.303 af Overall - 0.102 af Embedded = 0.201 af x 40.0% Voids
#2A	90.75'	0.102 af	ADS StormTech DC-780 +Cap x 96 Inside #1 Effective Size= 45.4"W x 30.0"H => 6.49 sf x 7.12'L = 46.2 cf Overall Size= 51.0"W x 30.0"H x 7.56'L with 0.44' Overlap 96 Chambers in 8 Rows
		0.182 af	Total Available Storage

Storage Group A created with Chamber Wizard

Device	Routing	Invert	Outlet Devices
#1	Discarded	90.00'	0.500 in/hr Exfiltration over Surface area Conductivity to Groundwater Elevation = 81.00'
#2	Primary	92.15'	6.0" W x 12.0" H Vert. Orifice1 C= 0.600 Limited to weir flow at low heads
#3	Primary	93.42'	48.0" W x 4.0" H Vert. Orifice #2 C= 0.600 Limited to weir flow at low heads

Discarded OutFlow Max=0.05 cfs @ 12.47 hrs HW=92.85' (Free Discharge)  
 1=Exfiltration ( Controls 0.05 cfs)

Primary OutFlow Max=0.94 cfs @ 12.47 hrs HW=92.85' (Free Discharge)  
 2=Orifice1 ( Orifice Controls 0.94 cfs @ 2.68 fps)  
 3=Orifice #2 ( Controls 0.00 cfs)

**Pond 8P: StormTech - Chamber Wizard Field A**

Chamber Model = ADS\_StormTech DC-780 +Cap (ADS StormTech® DC-780 with cap length)  
 Effective Size= 45.4"W x 30.0"H => 6.49 sf x 7.12'L = 46.2 cf  
 Overall Size= 51.0"W x 30.0"H x 7.56'L with 0.44' Overlap

51.0" Wide + 6.0" Spacing = 57.0" C-C Row Spacing

12 Chambers/Row x 7.12' Long +0.81' Cap Length x 2 = 87.06' Row Length +12.0" End Stone x 2 = 89.06' Base Length  
 8 Rows x 51.0" Wide + 6.0" Spacing x 7 + 12.0" Side Stone x 2 = 39.50' Base Width  
 9.0" Stone Base + 30.0" Chamber Height + 6.0" Stone Cover = 3.75' Field Height

96 Chambers x 46.2 cf = 4,438.9 cf Chamber Storage

13,191.5 cf Field - 4,438.9 cf Chambers = 8,752.6 cf Stone x 40.0% Voids = 3,501.0 cf Stone Storage

Chamber Storage + Stone Storage = 7,940.0 cf = 0.182 af  
 Overall Storage Efficiency = 60.2%  
 Overall System Size = 89.06' x 39.50' x 3.75'

96 Chambers  
 488.6 cy Field  
 324.2 cy Stone

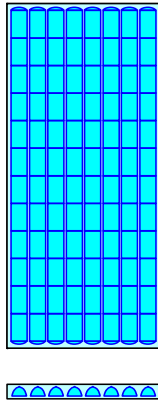

**Pond 8P: StormTech**

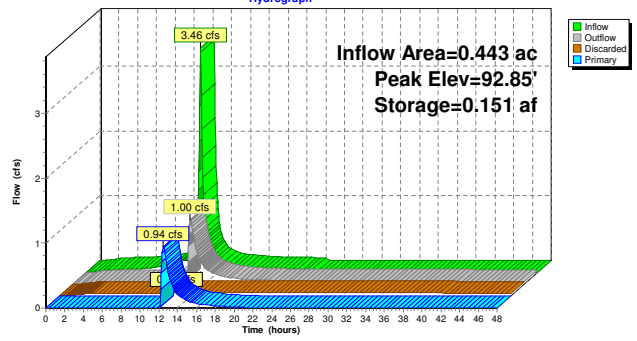

**Pond 8P: StormTech**

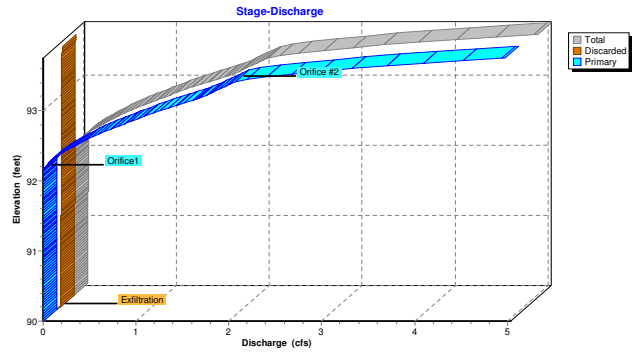

**Pond 8P: StormTech**

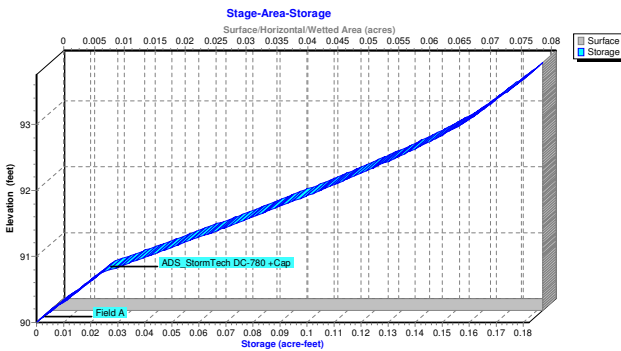

**Summary for Link 6L: POA #1**

Inflow Area = 8.568 ac, 64.37% Impervious, Inflow Depth = 6.79" for 100-Year (Current) event  
 Inflow = 48.91 cfs @ 12.13 hrs, Volume= 4.848 af  
 Primary = 48.91 cfs @ 12.13 hrs, Volume= 4.848 af, Atten= 0%, Lag= 0.0 min  
 Routed to nonexistent node 9L

Primary outflow = Inflow, Time Span= 0.00-48.00 hrs, dt= 0.05 hrs

**Link 6L: POA #1**

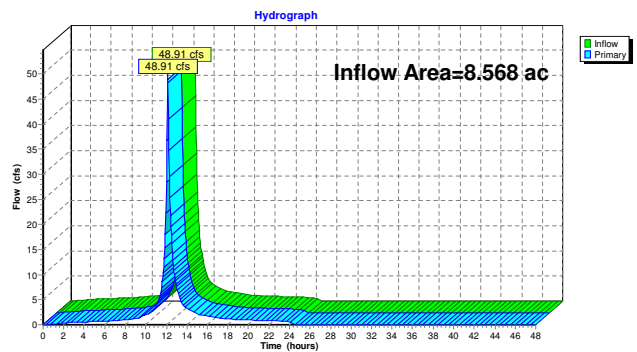

Summary for Link 7L: POA #2

Inflow Area = 0.546 ac, 51.83% Impervious, Inflow Depth = 6.30" for 100-Year (Current) event  
 Inflow = 3.95 cfs @ 12.10 hrs, Volume= 0.286 af  
 Primary = 3.95 cfs @ 12.10 hrs, Volume= 0.286 af, Atten= 0%, Lag= 0.0 min  
 Routed to nonexistent node 9L

Primary outflow = Inflow, Time Span= 0.00-48.00 hrs, dt= 0.05 hrs

Link 7L: POA #2

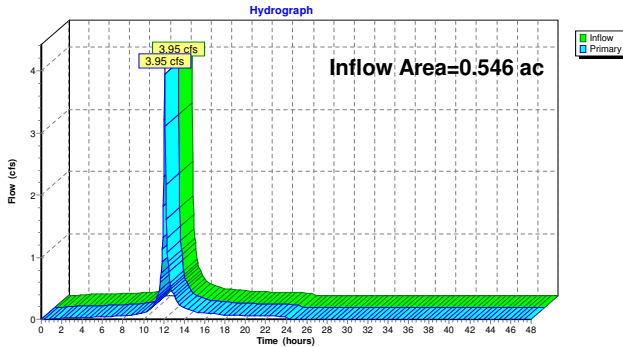

Time span=0.00-48.00 hrs, dt=0.05 hrs, 961 points  
 Runoff by SCS TR-20 method, UH=Delmarva, Split Pervious/Imperv.  
 Reach routing by Stor-Ind+Trans method - Pond routing by Stor-Ind method

- Subcatchment 1S: P-1B Impervious** Runoff Area=5.072 ac 100.00% Impervious Runoff Depth=1.03"  
 Flow Length=528' Tc=4.4 min CN=0/98 Runoff=13.21 cfs 0.437 af
  - Subcatchment 2S: P-2 Impervious** Runoff Area=0.283 ac 100.00% Impervious Runoff Depth=1.03"  
 Flow Length=237' Slope=0.0100 1/ Tc=2.7 min CN=0/98 Runoff=0.82 cfs 0.024 af
  - Subcatchment 3S: P-1B Pervious** Runoff Area=3.053 ac 0.00% Impervious Runoff Depth=0.01"  
 Flow Length=428' Tc=12.2 min CN=66/0 Runoff=0.04 cfs 0.002 af
  - Subcatchment 4S: P-2 Pervious** Runoff Area=0.263 ac 0.00% Impervious Runoff Depth=0.00"  
 Flow Length=43' Slope=0.0900 1/ Tc=2.7 min CN=61/0 Runoff=0.00 cfs 0.000 af
  - Subcatchment 11S: P-1A Impervious** Runoff Area=0.443 ac 100.00% Impervious Runoff Depth=1.03"  
 Tc=5.0 min CN=0/98 Runoff=1.10 cfs 0.038 af
  - Pond 8P: StormTech** Peak Elev=90.88' Storage=0.033 af Inflow=1.10 cfs 0.038 af  
 Discarded=0.04 cfs 0.038 af Primary=0.00 cfs 0.000 af Outflow=0.04 cfs 0.038 af
  - Link 6L: POA #1** Inflow=13.21 cfs 0.440 af  
 Primary=13.21 cfs 0.440 af
  - Link 7L: POA #2** Inflow=0.82 cfs 0.024 af  
 Primary=0.82 cfs 0.024 af
- Total Runoff Area = 9.114 ac Runoff Volume = 0.502 af Average Runoff Depth = 0.66"**  
**36.38% Pervious = 3.316 ac 63.62% Impervious = 5.798 ac**

Summary for Subcatchment 1S: P-1B Impervious

Runoff = 13.21 cfs @ 1.10 hrs, Volume= 0.437 af, Depth= 1.03"  
 Routed to Link 6L : POA #1

Runoff by SCS TR-20 method, UH=Delmarva, Split Pervious/Imperv., Time Span= 0.00-48.00 hrs, dt= 0.05 hrs  
 NJ DEP 2-hr WQ Rainfall=1.25"

Area (ac)	CN	Description			
5.072	98				
5.072	98	100.00% Impervious Area			
Tc (min)	Length (feet)	Slope (ft/ft)	Velocity (ft/sec)	Capacity (cfs)	Description
1.6	100	0.0100	1.06		Sheet Flow, Smooth surfaces n= 0.011 P2= 3.29"
2.8	428	0.0160	2.57		Shallow Concentrated Flow, Paved Kv= 20.3 fps
4.4	528	Total			

Subcatchment 1S: P-1B Impervious

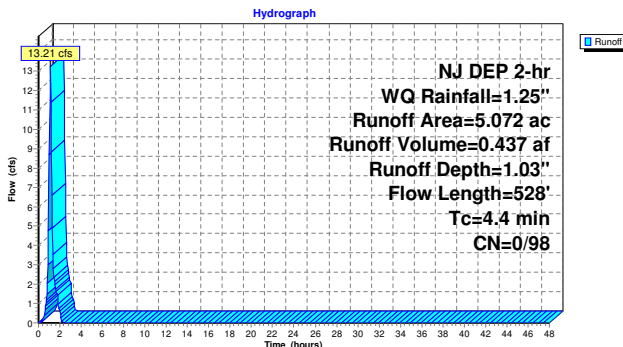

Summary for Subcatchment 2S: P-2 Impervious

Runoff = 0.82 cfs @ 1.08 hrs, Volume= 0.024 af, Depth= 1.03"  
 Routed to Link 7L : POA #2

Runoff by SCS TR-20 method, UH=Delmarva, Split Pervious/Imperv., Time Span= 0.00-48.00 hrs, dt= 0.05 hrs  
 NJ DEP 2-hr WQ Rainfall=1.25"

Area (ac)	CN	Description			
0.283	98				
0.283	98	100.00% Impervious Area			
Tc (min)	Length (feet)	Slope (ft/ft)	Velocity (ft/sec)	Capacity (cfs)	Description
1.6	100	0.0100	1.06		Sheet Flow, Smooth surfaces n= 0.011 P2= 3.29"
1.1	137	0.0100	2.03		Shallow Concentrated Flow, Paved Kv= 20.3 fps
2.7	237	Total			

Subcatchment 2S: P-2 Impervious

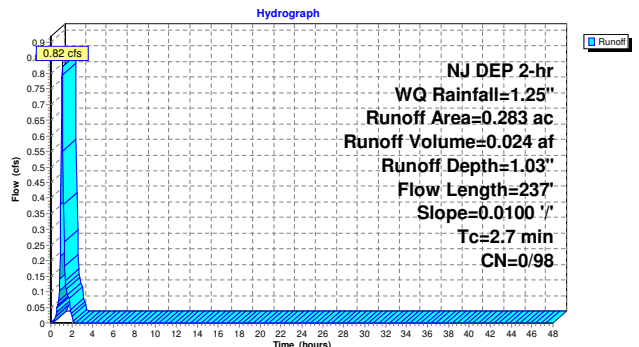

**Summary for Subcatchment 3S: P-1B Pervious**

Runoff = 0.04 cfs @ 1.84 hrs, Volume= 0.002 af, Depth= 0.01"  
 Routed to Link 6L : POA #1

Runoff by SCS TR-20 method, UH=Delmarva, Split Pervious/Imperv., Time Span= 0.00-48.00 hrs, dt= 0.05 hrs  
 NJ DEP 2-hr WQ Rainfall=1.25"

Area (ac)	CN	Description
1.849	61	>75% Grass cover, Good, HSG B
1.204	74	>75% Grass cover, Good, HSG C
3.053	66	Weighted Average
3.053	66	100.00% Pervious Area

Tc (min)	Length (feet)	Slope (ft/ft)	Velocity (ft/sec)	Capacity (cfs)	Description
9.7	100	0.0200	0.17		Sheet Flow, Grass: Short n= 0.150 P2= 3.29"
2.5	328	0.0180	2.16		Shallow Concentrated Flow, Unpaved Kv= 16.1 fps
12.2	428				Total

**Subcatchment 3S: P-1B Pervious**

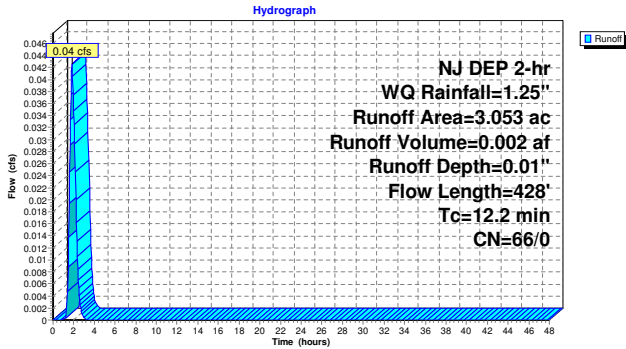

**Summary for Subcatchment 4S: P-2 Pervious**

Runoff = 0.00 cfs @ 0.00 hrs, Volume= 0.000 af, Depth= 0.00"  
 Routed to Link 7L : POA #2

Runoff by SCS TR-20 method, UH=Delmarva, Split Pervious/Imperv., Time Span= 0.00-48.00 hrs, dt= 0.05 hrs  
 NJ DEP 2-hr WQ Rainfall=1.25"

Area (ac)	CN	Description
0.263	61	>75% Grass cover, Good, HSG B
0.263	61	100.00% Pervious Area

Tc (min)	Length (feet)	Slope (ft/ft)	Velocity (ft/sec)	Capacity (cfs)	Description
2.7	43	0.0900	0.27		Sheet Flow, Grass: Short n= 0.150 P2= 3.29"

**Subcatchment 4S: P-2 Pervious**

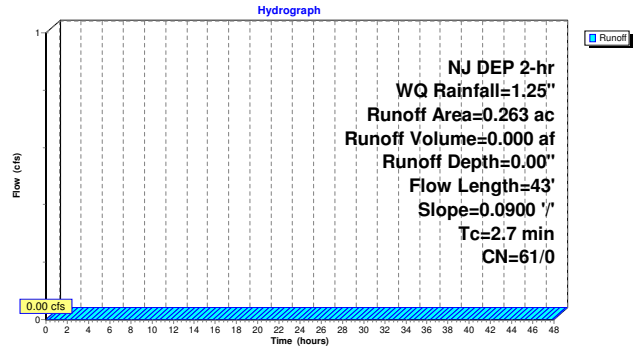

**Summary for Subcatchment 11S: P-1A Impervious**

Runoff = 1.10 cfs @ 1.11 hrs, Volume= 0.038 af, Depth= 1.03"  
 Routed to Pond 8P : StormTech

Runoff by SCS TR-20 method, UH=Delmarva, Split Pervious/Imperv., Time Span= 0.00-48.00 hrs, dt= 0.05 hrs  
 NJ DEP 2-hr WQ Rainfall=1.25"

Area (ac)	CN	Description
0.443	98	
0.443	98	100.00% Impervious Area

Tc (min)	Length (feet)	Slope (ft/ft)	Velocity (ft/sec)	Capacity (cfs)	Description
5.0					Direct Entry, roof

**Subcatchment 11S: P-1A Impervious**

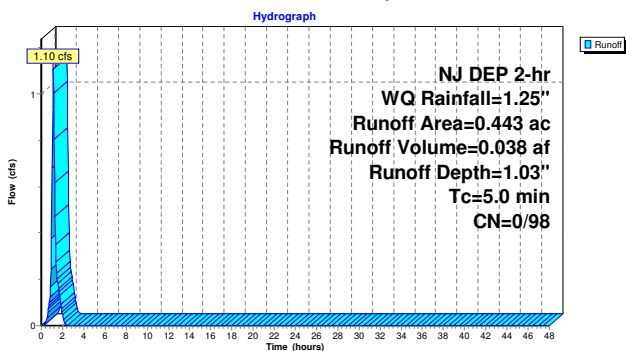

**Summary for Pond 8P: StormTech**

Inflow Area = 0.443 ac, 100.00% Impervious, Inflow Depth = 1.03" for WQ event  
 Inflow = 1.10 cfs @ 1.11 hrs, Volume= 0.038 af  
 Outflow = 0.04 cfs @ 2.03 hrs, Volume= 0.038 af, Atten= 96%, Lag= 55.7 min  
 Discarded = 0.04 cfs @ 2.03 hrs, Volume= 0.038 af  
 Primary = 0.00 cfs @ 0.00 hrs, Volume= 0.000 af  
 Routed to Link 6L : POA #1

Routing by Stor-Ind method, Time Span= 0.00-48.00 hrs, dt= 0.05 hrs  
 Peak Elev= 90.88' @ 2.03 hrs Surf. Area= 0.081 ac Storage= 0.033 af

Plug-Flow detention time= 284.4 min calculated for 0.038 af (100% of inflow)  
 Center-of-Mass det. time= 284.7 min ( 357.1 - 72.4 )

Volume	Invert	Avail. Storage	Storage Description
#1A	90.00'	0.080 af	39.50'W x 89.06'L x 3.75'H Field A 0.303 af Overall - 0.102 af Embedded = 0.201 af x 40.0% Voids
#2A	90.75'	0.102 af	ADS StormTech DC-780 +Cap x 96 Inside #1 Effective Size= 45.4"W x 30.0"H => 6.49 sf x 7.12'L = 46.2 cf Overall Size= 51.0"W x 30.0"H x 7.56'L with 0.44' Overlap 96 Chambers in 8 Rows
		0.182 af	Total Available Storage

Storage Group A created with Chamber Wizard

Device	Routing	Invert	Outlet Devices
#1	Discarded	90.00'	0.500 in/hr Exfiltration over Surface area Conductivity to Groundwater Elevation = 81.00'
#2	Primary	92.15'	6.0" W x 12.0" H Vert. Orifice1 C= 0.600 Limited to weir flow at low heads
#3	Primary	93.42'	48.0" W x 4.0" H Vert. Orifice #2 C= 0.600 Limited to weir flow at low heads

Discarded OutFlow Max=0.04 cfs @ 2.03 hrs HW=90.88' (Free Discharge)  
 1=Exfiltration ( Controls 0.04 cfs)

Primary OutFlow Max=0.00 cfs @ 0.00 hrs HW=90.00' (Free Discharge)  
 2=Orifice1 ( Controls 0.00 cfs)  
 3=Orifice #2 ( Controls 0.00 cfs)

**Pond 8P: StormTech - Chamber Wizard Field A**

Chamber Model = ADS\_StormTech DC-780 +Cap (ADS StormTech® DC-780 with cap length)  
 Effective Size= 45.4"W x 30.0"H => 6.49 sf x 7.12'L = 46.2 cf  
 Overall Size= 51.0"W x 30.0"H x 7.56'L with 0.44' Overlap  
 51.0" Wide + 6.0" Spacing = 57.0" C-C Row Spacing  
 12 Chambers/Row x 7.12' Long +0.81' Cap Length x 2 = 87.06' Row Length +12.0" End Stone x 2 = 89.06' Base Length  
 8 Rows x 51.0" Wide + 6.0" Spacing x 7 + 12.0" Side Stone x 2 = 39.50' Base Width  
 9.0" Stone Base + 30.0" Chamber Height + 6.0" Stone Cover = 3.75' Field Height  
 96 Chambers x 46.2 cf = 4,438.9 cf Chamber Storage  
 13,191.5 cf Field - 4,438.9 cf Chambers = 8,752.6 cf Stone x 40.0% Voids = 3,501.0 cf Stone Storage  
 Chamber Storage + Stone Storage = 7,940.0 cf = 0.182 af  
 Overall Storage Efficiency = 60.2%  
 Overall System Size = 89.06' x 39.50' x 3.75'

96 Chambers  
 488.6 cy Field  
 324.2 cy Stone

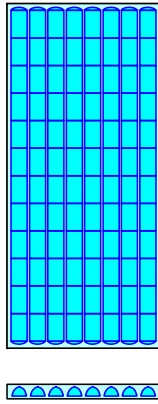

**Pond 8P: StormTech**

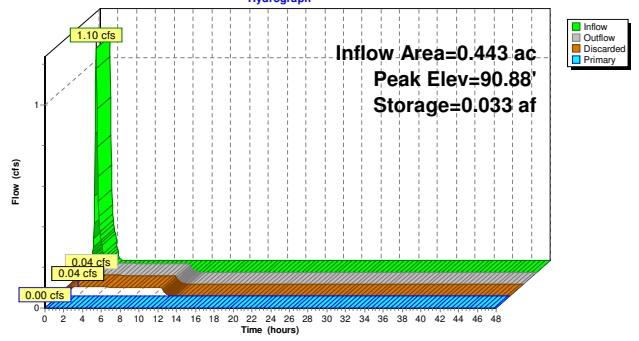

**Pond 8P: StormTech**

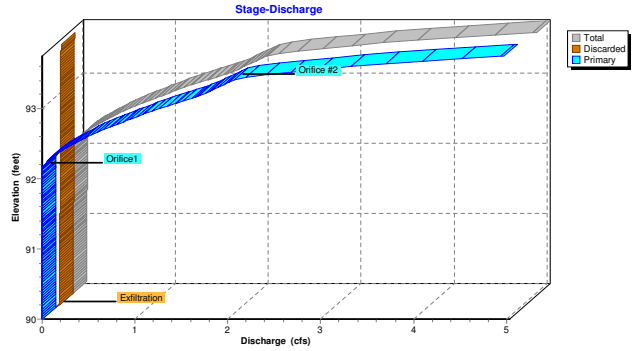

**Pond 8P: StormTech**

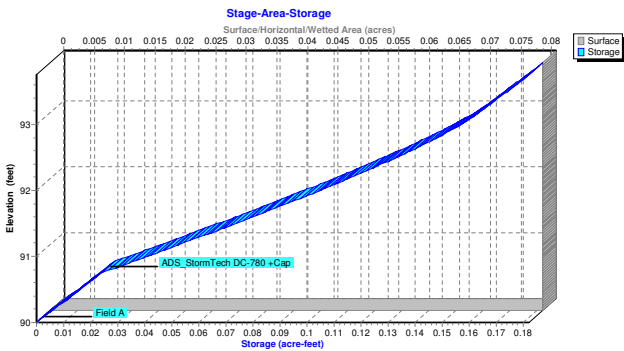

**Summary for Link 6L: POA #1**

Inflow Area = 8.568 ac, 64.37% Impervious, Inflow Depth = 0.62" for WQ event  
 Inflow = 13.21 cfs @ 1.10 hrs, Volume= 0.440 af  
 Primary = 13.21 cfs @ 1.10 hrs, Volume= 0.440 af, Atten= 0%, Lag= 0.0 min  
 Routed to nonexistent node 9L  
 Primary outflow = Inflow, Time Span= 0.00-48.00 hrs, dt= 0.05 hrs

**Link 6L: POA #1**

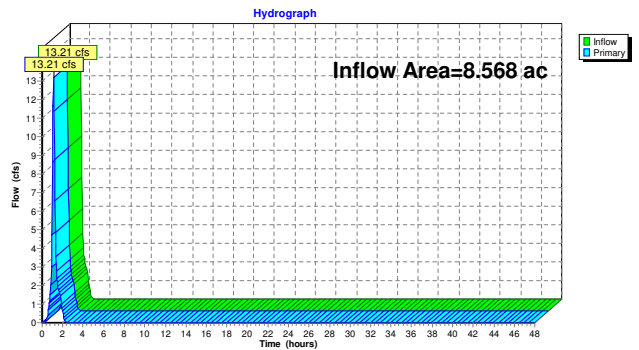

Summary for Link 7L: POA #2

Inflow Area = 0.546 ac, 51.83% Impervious, Inflow Depth = 0.54" for WQ event  
Inflow = 0.82 cfs @ 1.08 hrs, Volume= 0.024 af  
Primary = 0.82 cfs @ 1.08 hrs, Volume= 0.024 af, Atten= 0%, Lag= 0.0 min  
Routed to nonexistent node 9L

Primary outflow = Inflow, Time Span= 0.00-48.00 hrs, dt= 0.05 hrs

Link 7L: POA #2

Hydrograph

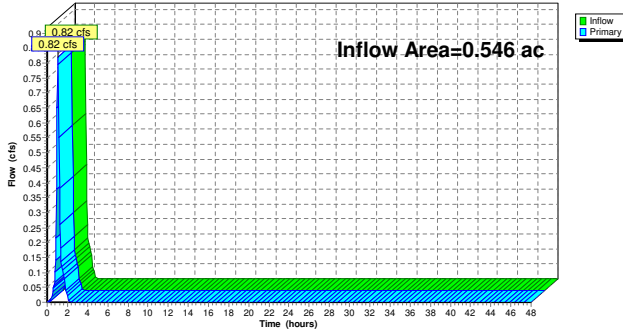

**Proposed Conditions-Future\_Rev1**

NOAA 24-hr C 2-Year (Future) Rainfall=3.88"

Prepared by Taylor, Wiseman, Taylor Printed 8/27/2025  
HydroCAD® 10.20.2h s/n 04583 © 2024 HydroCAD Software Solutions LLC Page 2

Time span=0.00-48.00 hrs, dt=0.05 hrs, 961 points  
Runoff by SCS TR-20 method, UH=Delmarva, Split Pervious/Imperv.  
Reach routing by Stor-Ind+Trans method - Pond routing by Stor-Ind method

- Subcatchment 1S: P-1B Impervious** Runoff Area=5.072 ac 100.00% Impervious Runoff Depth=3.65"  
Flow Length=528' Tc=4.3 min CN=0/98 Runoff=18.30 cfs 67,117 cf
- Subcatchment 2S: P-2 Impervious** Runoff Area=0.283 ac 100.00% Impervious Runoff Depth=3.65"  
Flow Length=237' Slope=0.0100 /' Tc=2.6 min CN=0/98 Runoff=1.16 cfs 3,745 cf
- Subcatchment 3S: P-1B Pervious** Runoff Area=3.053 ac 0.00% Impervious Runoff Depth=1.01"  
Flow Length=428' Tc=11.4 min CN=66/0 Runoff=2.10 cfs 11,248 cf
- Subcatchment 4S: P-2 Pervious** Runoff Area=0.263 ac 0.00% Impervious Runoff Depth=0.75"  
Flow Length=43' Slope=0.0900 /' Tc=2.5 min CN=61/0 Runoff=0.22 cfs 718 cf
- Subcatchment 11S: P-1A Impervious** Runoff Area=0.443 ac 100.00% Impervious Runoff Depth=3.65"  
Tc=5.0 min CN=0/98 Runoff=1.53 cfs 5,862 cf

- Pond 8P: StormTech** Peak Elev=91.58' Storage=0.079 af Inflow=1.53 cfs 5,862 cf  
Discarded=0.05 cfs 5,862 cf Primary=0.00 cfs 0 cf Outflow=0.05 cfs 5,862 cf
- Link 6L: POA #1** Inflow=19.72 cfs 78,365 cf  
Primary=19.72 cfs 78,365 cf
- Link 7L: POA #2** Inflow=1.38 cfs 4,463 cf  
Primary=1.38 cfs 4,463 cf

**Total Runoff Area = 397,006 sf Runoff Volume = 88,690 cf Average Runoff Depth = 2.68"**  
36.38% Pervious = 144,445 sf 63.62% Impervious = 252,561 sf

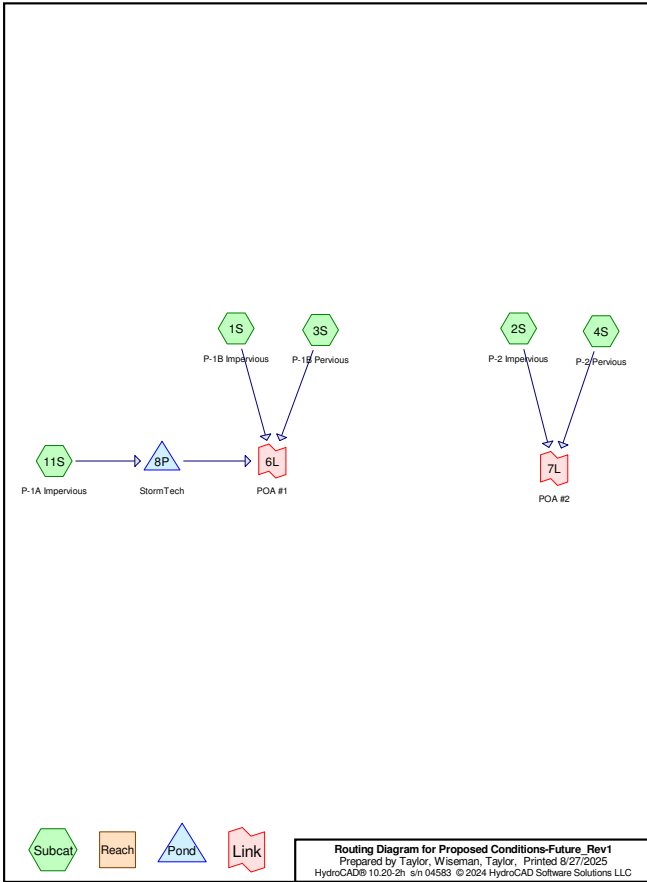

**Proposed Conditions-Future\_Rev1**

NOAA 24-hr C 2-Year (Future) Rainfall=3.88"

Prepared by Taylor, Wiseman, Taylor Printed 8/27/2025  
HydroCAD® 10.20.2h s/n 04583 © 2024 HydroCAD Software Solutions LLC Page 3

**Summary for Subcatchment 1S: P-1B Impervious**

Runoff = 18.30 cfs @ 12.12 hrs, Volume= 67,117 cf, Depth= 3.65"  
Routed to Link 6L : POA #1

Runoff by SCS TR-20 method, UH=Delmarva, Split Pervious/Imperv., Time Span= 0.00-48.00 hrs, dt= 0.05 hrs  
NOAA 24-hr C 2-Year (Future) Rainfall=3.88"

Area (ac)	CN	Description
* 5.072	98	
5.072	98	100.00% Impervious Area

Tc (min)	Length (feet)	Slope (ft/ft)	Velocity (ft/sec)	Capacity (cfs)	Description
1.5	100	0.0100	1.15		Sheet Flow, Smooth surfaces n= 0.011 P2= 3.88"
2.8	428	0.0160	2.57		Shallow Concentrated Flow, Paved Kv= 20.3 fps
4.3	528	Total			

**Subcatchment 1S: P-1B Impervious**

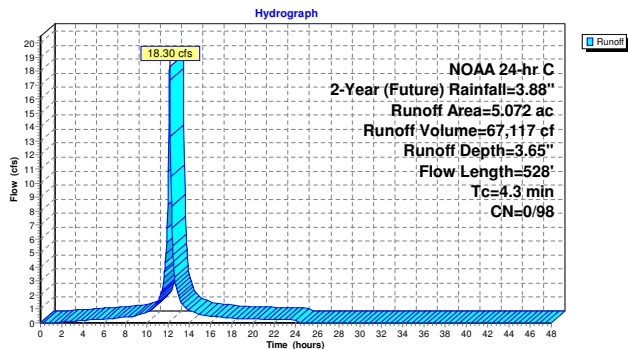

**Proposed Conditions-Future\_Rev1**

NOAA 24-hr C 2-Year (Future) Rainfall=3.88"

Prepared by Taylor, Wiseman, Taylor Printed 8/27/2025  
HydroCAD® 10.20.2h s/n 04583 © 2024 HydroCAD Software Solutions LLC Page 4

**Summary for Subcatchment 2S: P-2 Impervious**

Runoff = 1.16 cfs @ 12.10 hrs, Volume= 3,745 cf, Depth= 3.65"  
Routed to Link 7L : POA #2

Runoff by SCS TR-20 method, UH=Delmarva, Split Pervious/Imperv., Time Span= 0.00-48.00 hrs, dt= 0.05 hrs  
NOAA 24-hr C 2-Year (Future) Rainfall=3.88"

Area (ac)	CN	Description
* 0.283	98	
0.283	98	100.00% Impervious Area

Tc (min)	Length (feet)	Slope (ft/ft)	Velocity (ft/sec)	Capacity (cfs)	Description
1.5	100	0.0100	1.15		Sheet Flow, Smooth surfaces n= 0.011 P2= 3.88"
1.1	137	0.0100	2.03		Shallow Concentrated Flow, Paved Kv= 20.3 fps
2.6	237	Total			

**Subcatchment 2S: P-2 Impervious**

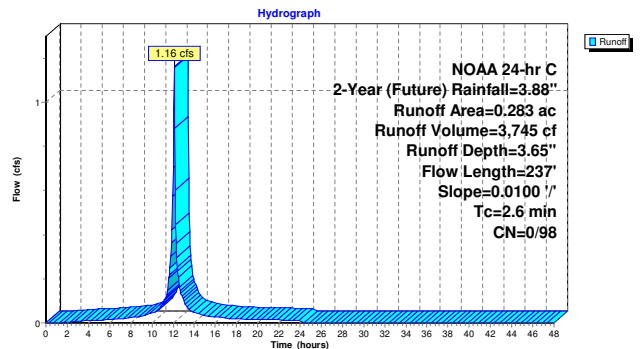

**Summary for Subcatchment 3S: P-1B Pervious**

Runoff = 2.10 cfs @ 12.24 hrs, Volume= 11,248 cf, Depth= 1.01"  
 Routed to Link 6L : POA #1

Runoff by SCS TR-20 method, UH=Delmarva, Split Pervious/Imperv., Time Span= 0.00-48.00 hrs, dt= 0.05 hrs  
 NOAA 24-hr C 2-Year (Future) Rainfall=3.88"

Area (ac)	CN	Description
1.849	61	>75% Grass cover, Good, HSG B
1.204	74	>75% Grass cover, Good, HSG C
3.053	66	Weighted Average
3.053	66	100.00% Pervious Area

Tc (min)	Length (feet)	Slope (ft/ft)	Velocity (ft/sec)	Capacity (cfs)	Description
8.9	100	0.0200	0.19		Sheet Flow, Grass: Short n= 0.150 P2= 3.88"
2.5	328	0.0180	2.16		Shallow Concentrated Flow, Unpaved Kv= 16.1 fps
11.4	428				Total

**Subcatchment 3S: P-1B Pervious**

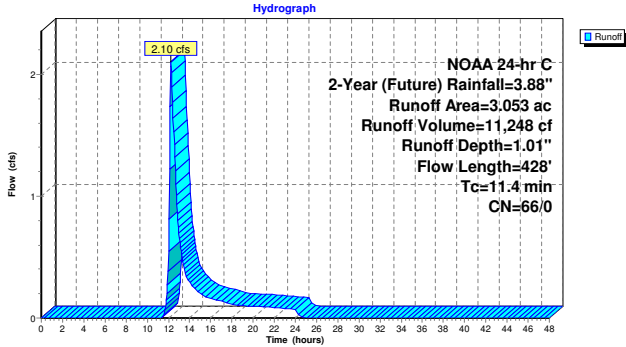

**Summary for Subcatchment 4S: P-2 Pervious**

Runoff = 0.22 cfs @ 12.11 hrs, Volume= 718 cf, Depth= 0.75"  
 Routed to Link 7L : POA #2

Runoff by SCS TR-20 method, UH=Delmarva, Split Pervious/Imperv., Time Span= 0.00-48.00 hrs, dt= 0.05 hrs  
 NOAA 24-hr C 2-Year (Future) Rainfall=3.88"

Area (ac)	CN	Description
0.263	61	>75% Grass cover, Good, HSG B
0.263	61	100.00% Pervious Area

Tc (min)	Length (feet)	Slope (ft/ft)	Velocity (ft/sec)	Capacity (cfs)	Description
2.5	43	0.0900	0.29		Sheet Flow, Grass: Short n= 0.150 P2= 3.88"

**Subcatchment 4S: P-2 Pervious**

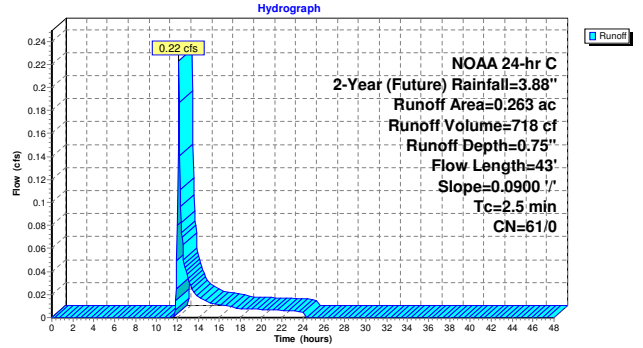

**Summary for Subcatchment 11S: P-1A Impervious**

Runoff = 1.53 cfs @ 12.13 hrs, Volume= 5,862 cf, Depth= 3.65"  
 Routed to Pond 8P : StormTech

Runoff by SCS TR-20 method, UH=Delmarva, Split Pervious/Imperv., Time Span= 0.00-48.00 hrs, dt= 0.05 hrs  
 NOAA 24-hr C 2-Year (Future) Rainfall=3.88"

Area (ac)	CN	Description
0.443	98	
0.443	98	100.00% Impervious Area

Tc (min)	Length (feet)	Slope (ft/ft)	Velocity (ft/sec)	Capacity (cfs)	Description
5.0					Direct Entry, roof

**Subcatchment 11S: P-1A Impervious**

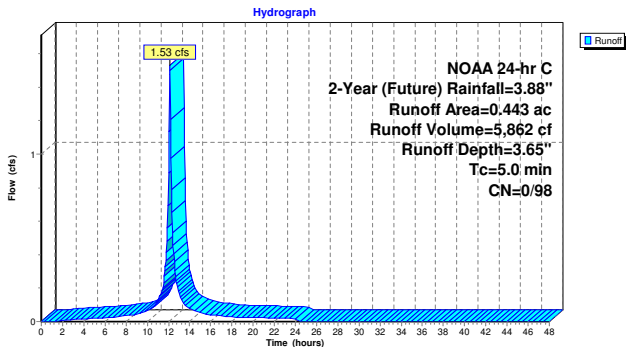

**Summary for Pond 8P: StormTech**

Inflow Area = 19,297 sf, 100.00% Impervious, Inflow Depth = 3.65" for 2-Year (Future) event  
 Inflow = 1.53 cfs @ 12.13 hrs, Volume= 5,862 cf  
 Outflow = 0.05 cfs @ 15.28 hrs, Volume= 5,862 cf, Atten= 97%, Lag= 189.1 min  
 Discarded = 0.05 cfs @ 15.28 hrs, Volume= 5,862 cf  
 Primary = 0.00 cfs @ 0.00 hrs, Volume= 0 cf  
 Routed to Link 6L : POA #1

Routing by Stor-Ind method, Time Span= 0.00-48.00 hrs, dt= 0.05 hrs  
 Peak Elev= 91.58' @ 15.28 hrs Surf.Area= 0.081 ac Storage= 0.079 af

Plug-Flow detention time= 650.9 min calculated for 5,856 cf (100% of inflow)  
 Center-of-Mass det. time= 651.4 min ( 1,407.0 - 755.7 )

Volume	Invert	Avail.Storage	Storage Description
#1A	90.00'	0.080 af	39.50'W x 89.06'L x 3.75'H Field A 0.303 af Overall - 0.102 af Embedded = 0.201 af x 40.0% Voids
#2A	90.75'	0.102 af	ADS StormTech DC-780 +Cap x 96 Inside #1 Effective Size= 45.4"W x 30.0"H => 6.49 sf x 7.12'L = 46.2 cf Overall Size= 51.0"W x 30.0"H x 7.56'L with 0.44' Overlap 96 Chambers in 8 Rows
		0.182 af	Total Available Storage

Storage Group A created with Chamber Wizard

Device	Routing	Invert	Outlet Devices
#1	Discarded	90.00'	0.500 in/hr Exfiltration over Surface area Conductivity to Groundwater Elevation = 81.00'
#2	Primary	92.15'	6.0" W x 12.0" H Vert. Orifice1 C= 0.600 Limited to weir flow at low heads
#3	Primary	93.42'	48.0" W x 4.0" H Vert. Orifice #2 C= 0.600 Limited to weir flow at low heads

Discarded OutFlow Max=0.05 cfs @ 15.28 hrs HW=91.58' (Free Discharge)  
 1=Exfiltration ( Controls 0.05 cfs)

Primary OutFlow Max=0.00 cfs @ 0.00 hrs HW=90.00' (Free Discharge)  
 2=Orifice1 ( Controls 0.00 cfs)  
 3=Orifice #2 ( Controls 0.00 cfs)

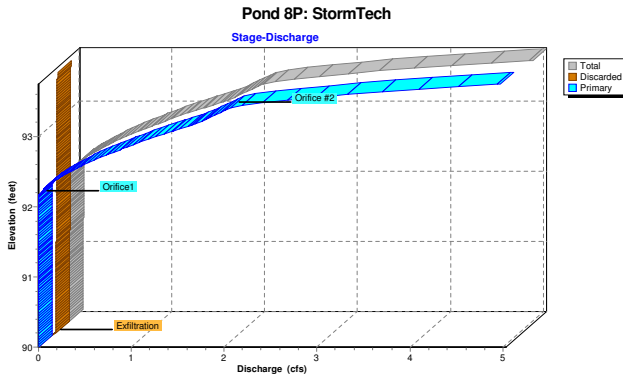
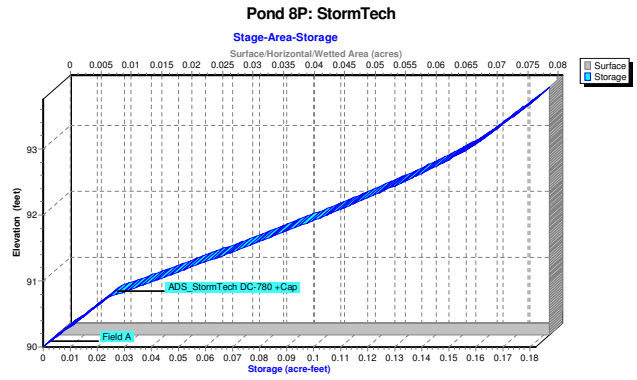
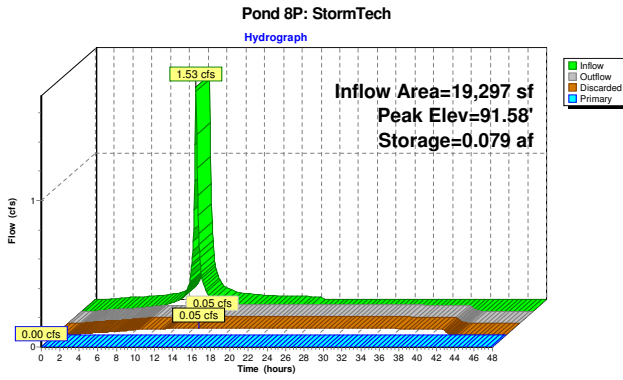

**Summary for Link 6L: POA #1**

Inflow Area = 373,222 sf, 64.37% Impervious, Inflow Depth = 2.52" for 2-Year (Future) event  
 Inflow = 19.72 cfs @ 12.12 hrs, Volume= 78,365 cf  
 Primary = 19.72 cfs @ 12.12 hrs, Volume= 78,365 cf, Atten= 0%, Lag= 0.0 min  
 Routed to nonexistent node 10L

Primary outflow = Inflow, Time Span= 0.00-48.00 hrs, dt= 0.05 hrs

**Link 6L: POA #1**

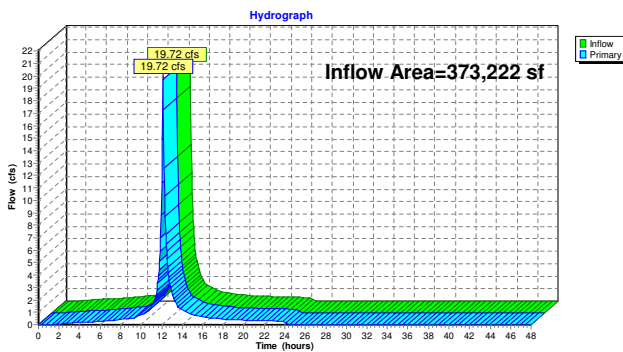

**Summary for Link 7L: POA #2**

Inflow Area = 23,784 sf, 51.83% Impervious, Inflow Depth = 2.25" for 2-Year (Future) event  
 Inflow = 1.38 cfs @ 12.10 hrs, Volume= 4,463 cf  
 Primary = 1.38 cfs @ 12.10 hrs, Volume= 4,463 cf, Atten= 0%, Lag= 0.0 min  
 Routed to nonexistent node 10L

Primary outflow = Inflow, Time Span= 0.00-48.00 hrs, dt= 0.05 hrs

**Link 7L: POA #2**

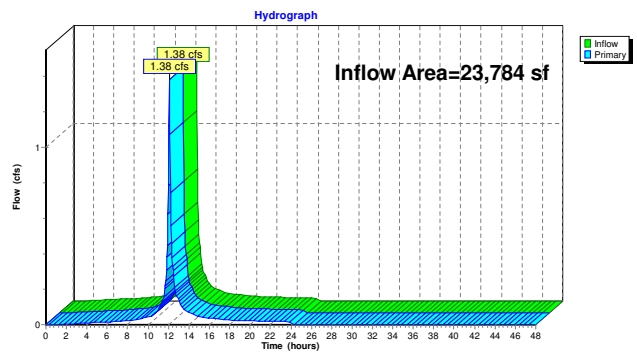

Time span=0.00-48.00 hrs, dt=0.05 hrs, 961 points  
 Runoff by SCS TR-20 method, UH=Delmarva, Split Pervious/Imperv.  
 Reach routing by Stor-Ind+Trans method - Pond routing by Stor-Ind method

**Subcatchment 1S: P-1B Impervious** Runoff Area=5.072 ac 100.00% Impervious Runoff Depth=5.71"  
 Flow Length=528' Tc=4.3 min CN=0/98 Runoff=28.20 cfs 105,164 cf

**Subcatchment 2S: P-2 Impervious** Runoff Area=0.283 ac 100.00% Impervious Runoff Depth=5.71"  
 Flow Length=237' Slope=0.0100 /' Tc=2.6 min CN=0/98 Runoff=1.79 cfs 5,868 cf

**Subcatchment 3S: P-1B Pervious** Runoff Area=3.053 ac 0.00% Impervious Runoff Depth=2.40"  
 Flow Length=428' Tc=11.4 min CN=66/0 Runoff=5.58 cfs 26,634 cf

**Subcatchment 4S: P-2 Pervious** Runoff Area=0.263 ac 0.00% Impervious Runoff Depth=1.97"  
 Flow Length=43' Slope=0.0900 /' Tc=2.5 min CN=61/0 Runoff=0.67 cfs 1,883 cf

**Subcatchment 11S: P-1A Impervious** Runoff Area=0.443 ac 100.00% Impervious Runoff Depth=5.71"  
 Tc=5.0 min CN=0/98 Runoff=2.36 cfs 9,185 cf

**Pond 8P: StormTch** Peak Elev=92.31' Storage=0.123 af Inflow=2.36 cfs 9,185 cf  
 Discarded=0.05 cfs 7,513 cf Primary=0.11 cfs 996 cf Outflow=0.16 cfs 8,508 cf

**Link 6L: POA #1** Inflow=32.21 cfs 132,793 cf  
 Primary=32.21 cfs 132,793 cf

**Link 7L: POA #2** Inflow=2.45 cfs 7,751 cf  
 Primary=2.45 cfs 7,751 cf

**Total Runoff Area = 397,006 sf Runoff Volume = 148,733 cf Average Runoff Depth = 4.50"**  
**36.38% Pervious = 144,445 sf 63.62% Impervious = 252,561 sf**

**Summary for Subcatchment 1S: P-1B Impervious**

Runoff = 28.20 cfs @ 12.12 hrs, Volume= 105,164 cf, Depth= 5.71"  
 Routed to Link 6L : POA #1

Runoff by SCS TR-20 method, UH=Delmarva, Split Pervious/Imperv., Time Span= 0.00-48.00 hrs, dt= 0.05 hrs  
 NOAA 24-hr C 10-Year (Future) Rainfall=5.95"

Area (ac)	CN	Description
5.072	98	
5.072	98	100.00% Impervious Area

Tc (min)	Length (feet)	Slope (ft/ft)	Velocity (ft/sec)	Capacity (cfs)	Description
1.5	100	0.0100	1.15		Sheet Flow, Smooth surfaces n= 0.011 P2= 3.88"
2.8	428	0.0160	2.57		Shallow Concentrated Flow, Paved Kv= 20.3 fps
4.3	528	Total			

**Subcatchment 1S: P-1B Impervious**

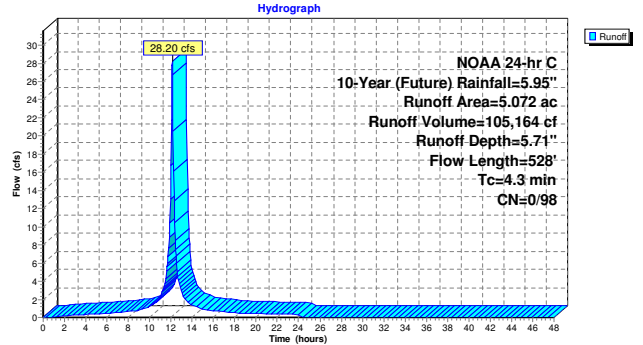

**Summary for Subcatchment 2S: P-2 Impervious**

Runoff = 1.79 cfs @ 12.10 hrs, Volume= 5,868 cf, Depth= 5.71"  
 Routed to Link 7L : POA #2

Runoff by SCS TR-20 method, UH=Delmarva, Split Pervious/Imperv., Time Span= 0.00-48.00 hrs, dt= 0.05 hrs  
 NOAA 24-hr C 10-Year (Future) Rainfall=5.95"

Area (ac)	CN	Description
0.283	98	
0.283	98	100.00% Impervious Area

Tc (min)	Length (feet)	Slope (ft/ft)	Velocity (ft/sec)	Capacity (cfs)	Description
1.5	100	0.0100	1.15		Sheet Flow, Smooth surfaces n= 0.011 P2= 3.88"
1.1	137	0.0100	2.03		Shallow Concentrated Flow, Paved Kv= 20.3 fps
2.6	237	Total			

**Subcatchment 2S: P-2 Impervious**

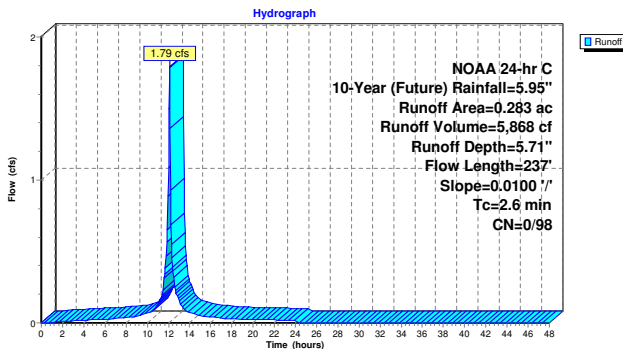

**Summary for Subcatchment 3S: P-1B Pervious**

Runoff = 5.58 cfs @ 12.22 hrs, Volume= 26,634 cf, Depth= 2.40"  
 Routed to Link 6L : POA #1

Runoff by SCS TR-20 method, UH=Delmarva, Split Pervious/Imperv., Time Span= 0.00-48.00 hrs, dt= 0.05 hrs  
 NOAA 24-hr C 10-Year (Future) Rainfall=5.95"

Area (ac)	CN	Description
1.849	61	>75% Grass cover, Good, HSG B
1.204	74	>75% Grass cover, Good, HSG C
3.053	66	Weighted Average
3.053	66	100.00% Pervious Area

Tc (min)	Length (feet)	Slope (ft/ft)	Velocity (ft/sec)	Capacity (cfs)	Description
8.9	100	0.0200	0.19		Sheet Flow, Grass: Short n= 0.150 P2= 3.88"
2.5	328	0.0180	2.16		Shallow Concentrated Flow, Unpaved Kv= 16.1 fps
11.4	428	Total			

**Subcatchment 3S: P-1B Pervious**

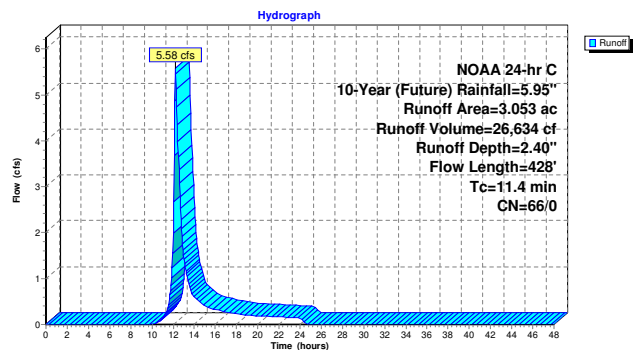

**Summary for Subcatchment 4S: P-2 Pervious**

Runoff = 0.67 cfs @ 12.10 hrs, Volume= 1,883 cf, Depth= 1.97"  
 Routed to Link 7L : POA #2

Runoff by SCS TR-20 method, UH=Delmarva, Split Pervious/Imperv., Time Span= 0.00-48.00 hrs, dt= 0.05 hrs  
 NOAA 24-hr C 10-Year (Future) Rainfall=5.95"

Area (ac)	CN	Description
0.263	61	>75% Grass cover, Good, HSG B
0.263	61	100.00% Pervious Area

Tc (min)	Length (feet)	Slope (ft/ft)	Velocity (ft/sec)	Capacity (cfs)	Description
2.5	43	0.0900	0.29		Sheet Flow, Grass: Short n= 0.150 P2= 3.88"

**Subcatchment 4S: P-2 Pervious**

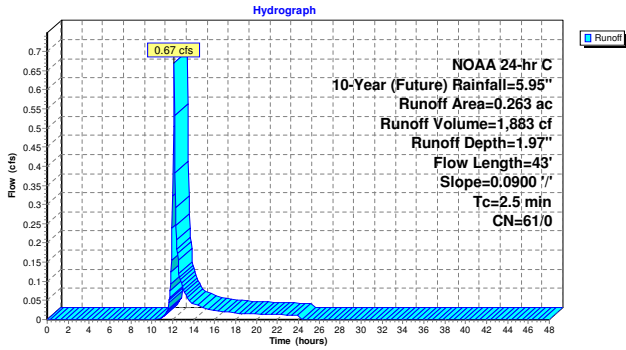

**Summary for Subcatchment 11S: P-1A Impervious**

Runoff = 2.36 cfs @ 12.13 hrs, Volume= 9,185 cf, Depth= 5.71"  
 Routed to Pond 8P : StormTech

Runoff by SCS TR-20 method, UH=Delmarva, Split Pervious/Imperv., Time Span= 0.00-48.00 hrs, dt= 0.05 hrs  
 NOAA 24-hr C 10-Year (Future) Rainfall=5.95"

Area (ac)	CN	Description
0.443	98	
0.443	98	100.00% Impervious Area

Tc (min)	Length (feet)	Slope (ft/ft)	Velocity (ft/sec)	Capacity (cfs)	Description
5.0					Direct Entry, roof

**Subcatchment 11S: P-1A Impervious**

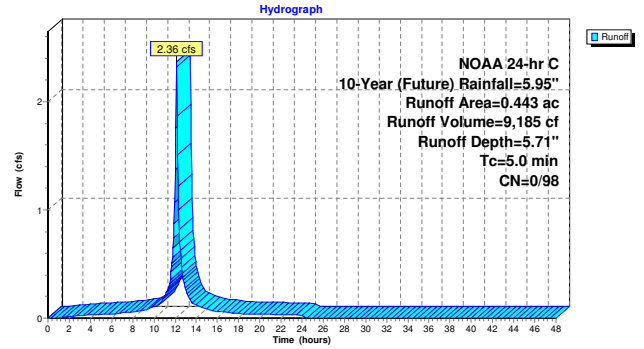

**Summary for Pond 8P: StormTech**

Inflow Area = 19,297 sf, 100.00% Impervious, Inflow Depth = 5.71" for 10-Year (Future) event  
 Inflow = 2.36 cfs @ 12.13 hrs, Volume= 9,185 cf  
 Outflow = 0.16 cfs @ 13.53 hrs, Volume= 8,508 cf, Atten= 93%, Lag= 83.9 min  
 Discarded = 0.05 cfs @ 13.53 hrs, Volume= 7,513 cf  
 Primary = 0.11 cfs @ 13.53 hrs, Volume= 996 cf  
 Routed to Link 6L : POA #1

Routing by Stor-Ind method, Time Span= 0.00-48.00 hrs, dt= 0.05 hrs  
 Peak Elev= 92.31' @ 13.53 hrs Surf.Area= 0.081 ac Storage= 0.123 af

Plug-Flow detention time= 757.4 min calculated for 8,508 cf (93% of inflow)  
 Center-of-Mass det. time= 715.7 min ( 1,463.8 - 748.1 )

Volume	Invert	Avail. Storage	Storage Description
#1A	90.00'	0.080 af	39.50'W x 89.06'L x 3.75'H Field A 0.303 af Overall - 0.102 af Embedded = 0.201 af x 40.0% Voids
#2A	90.75'	0.102 af	ADS StormTech DC-780 +Cap x 96 Inside #1 Effective Size= 45.4"W x 30.0"H => 6.49 sf x 7.12'L = 46.2 cf Overall Size= 51.0"W x 30.0"H x 7.56'L with 0.44' Overlap 96 Chambers in 8 Rows
		0.182 af	Total Available Storage

Storage Group A created with Chamber Wizard

Device	Routing	Invert	Outlet Devices
#1	Discarded	90.00'	0.500 in/hr Exfiltration over Surface area Conductivity to Groundwater Elevation = 81.00'
#2	Primary	92.15'	6.0" W x 12.0" H Vert. Orifice1 C= 0.600 Limited to weir flow at low heads
#3	Primary	93.42'	48.0" W x 4.0" H Vert. Orifice #2 C= 0.600 Limited to weir flow at low heads

**Discarded OutFlow** Max=0.05 cfs @ 13.53 hrs HW=92.31' (Free Discharge)  
 1=Exfiltration ( Controls 0.05 cfs)

**Primary OutFlow** Max=0.11 cfs @ 13.53 hrs HW=92.31' (Free Discharge)  
 2=Orifice1 ( Orifice Controls 0.11 cfs @ 1.30 fps)  
 3=Orifice #2 ( Controls 0.00 cfs)

**Pond 8P: StormTech**

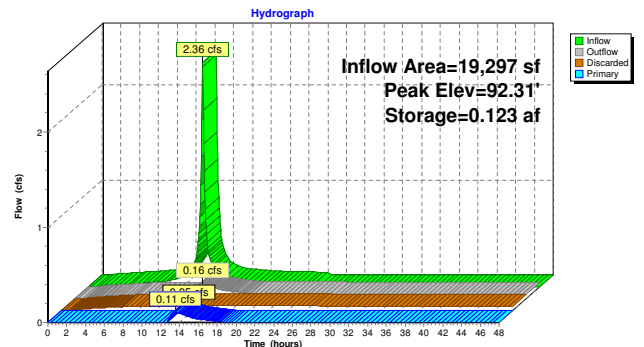

**Pond 8P: StormTech**

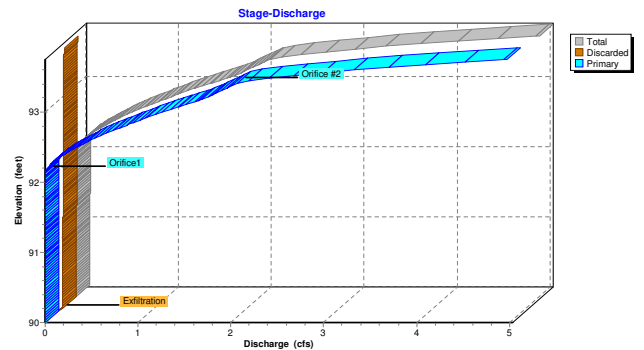

**Pond 8P: StormTech**

**Stage-Area-Storage**

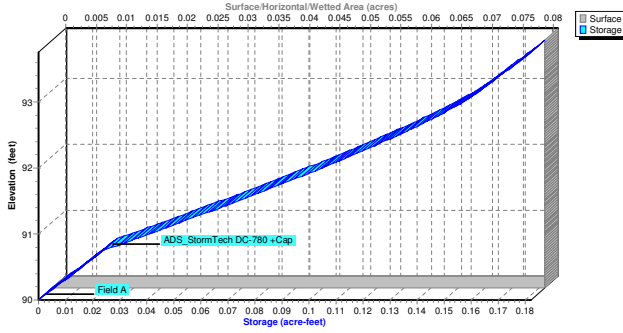

**Summary for Link 6L: POA #1**

Inflow Area = 373,222 sf, 64.37% Impervious, Inflow Depth = 4.27" for 10-Year (Future) event  
 Inflow = 32.21 cfs @ 12.13 hrs, Volume= 132,793 cf  
 Primary = 32.21 cfs @ 12.13 hrs, Volume= 132,793 cf, Atten= 0%, Lag= 0.0 min  
 Routed to nonexistent node 10L

Primary outflow = Inflow, Time Span= 0.00-48.00 hrs, dt= 0.05 hrs

**Link 6L: POA #1**

**Hydrograph**

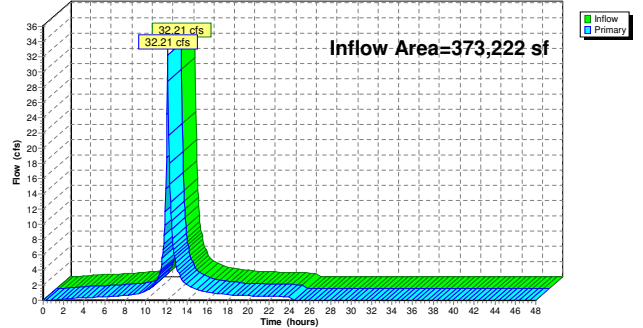

**Summary for Link 7L: POA #2**

Inflow Area = 23,784 sf, 51.83% Impervious, Inflow Depth = 3.91" for 10-Year (Future) event  
 Inflow = 2.45 cfs @ 12.10 hrs, Volume= 7,751 cf  
 Primary = 2.45 cfs @ 12.10 hrs, Volume= 7,751 cf, Atten= 0%, Lag= 0.0 min  
 Routed to nonexistent node 10L

Primary outflow = Inflow, Time Span= 0.00-48.00 hrs, dt= 0.05 hrs

**Link 7L: POA #2**

**Hydrograph**

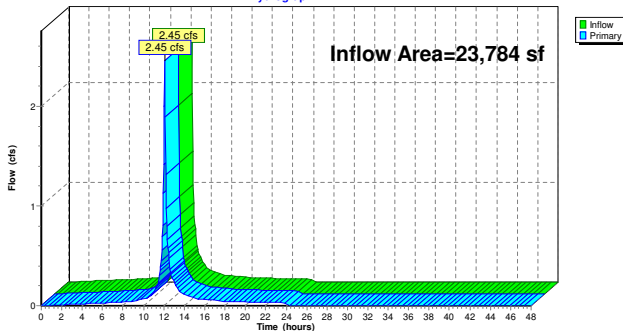

Time span=0.00-48.00 hrs, dt=0.05 hrs, 961 points  
 Runoff by SCS TR-20 method, UH=Delmarva, Split Pervious/Imperv.  
 Reach routing by Stor-Ind+Trans method - Pond routing by Stor-Ind method

**Subcatchment 1S: P-1B Impervious** Runoff Area=5.072 ac 100.00% Impervious Runoff Depth=10.80"  
 Flow Length=528' Tc=4.3 min CN=0/98 Runoff=52.48 cfs 198,821 cf

**Subcatchment 2S: P-2 Impervious** Runoff Area=0.283 ac 100.00% Impervious Runoff Depth=10.80"  
 Flow Length=237' Slope=0.0100 1/ Tc=2.6 min CN=0/98 Runoff=3.33 cfs 11,094 cf

**Subcatchment 3S: P-1B Pervious** Runoff Area=3.053 ac 0.00% Impervious Runoff Depth=6.61"  
 Flow Length=428' Tc=11.4 min CN=66/0 Runoff=15.77 cfs 73,239 cf

**Subcatchment 4S: P-2 Pervious** Runoff Area=0.263 ac 0.00% Impervious Runoff Depth=5.90"  
 Flow Length=43' Slope=0.0900 1/ Tc=2.5 min CN=61/0 Runoff=2.04 cfs 5,631 cf

**Subcatchment 11S: P-1A Impervious** Runoff Area=0.443 ac 100.00% Impervious Runoff Depth=10.80"  
 Tc=5.0 min CN=0/98 Runoff=4.40 cfs 17,365 cf

**Pond 8P: StormTech** Peak Elev=93.44' Storage=0.172 af Inflow=4.40 cfs 17,365 cf  
 Discarded=0.06 cfs 7,941 cf Primary=2.16 cfs 8,453 cf Outflow=2.21 cfs 16,395 cf

**Link 6L: POA #1** Inflow=65.78 cfs 280,513 cf  
 Primary=65.78 cfs 280,513 cf

**Link 7L: POA #2** Inflow=5.37 cfs 16,724 cf  
 Primary=5.37 cfs 16,724 cf

**Total Runoff Area = 397,006 sf Runoff Volume = 306,150 cf Average Runoff Depth = 9.25"**  
 36.38% Pervious = 144,445 sf 63.62% Impervious = 252,561 sf

**Summary for Subcatchment 1S: P-1B Impervious**

Runoff = 52.48 cfs @ 12.12 hrs, Volume= 198,821 cf, Depth=10.80"  
 Routed to Link 6L : POA #1

Runoff by SCS TR-20 method, UH=Delmarva, Split Pervious/Imperv., Time Span= 0.00-48.00 hrs, dt= 0.05 hrs  
 NOAA 24-hr C 100-Year (Future) Rainfall=11.04"

Area (ac)	CN	Description
5.072	98	
5.072	98	100.00% Impervious Area

Tc (min)	Length (feet)	Slope (ft/ft)	Velocity (ft/sec)	Capacity (cfs)	Description
1.5	100	0.0100	1.15		Sheet Flow, Smooth surfaces n= 0.011 P2= 3.88"
2.8	428	0.0160	2.57		Shallow Concentrated Flow, Paved Kv= 20.3 fps
4.3	528				Total

**Subcatchment 1S: P-1B Impervious**

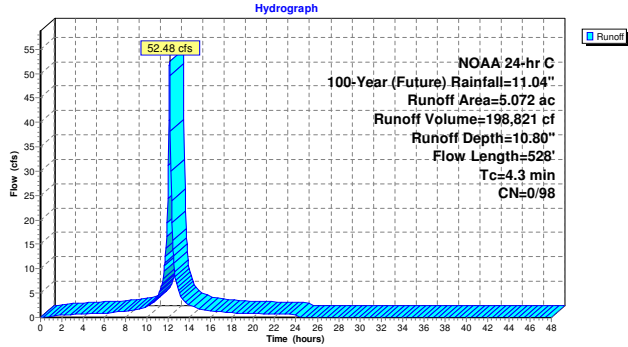

**Summary for Subcatchment 2S: P-2 Impervious**

Runoff = 3.33 cfs @ 12.10 hrs, Volume= 11,094 cf, Depth=10.80"  
 Routed to Link 7L : POA #2

Runoff by SCS TR-20 method, UH=Delmarva, Split Pervious/Imperv., Time Span= 0.00-48.00 hrs, dt= 0.05 hrs  
 NOAA 24-hr C 100-Year (Future) Rainfall=11.04"

Area (ac)	CN	Description
0.283	98	
0.283	98	100.00% Impervious Area

Tc (min)	Length (feet)	Slope (ft/ft)	Velocity (ft/sec)	Capacity (cfs)	Description
1.5	100	0.0100	1.15		Sheet Flow, Smooth surfaces n= 0.011 P2= 3.88"
1.1	137	0.0100	2.03		Shallow Concentrated Flow, Paved Kv= 20.3 fps
2.6	237				Total

**Subcatchment 2S: P-2 Impervious**

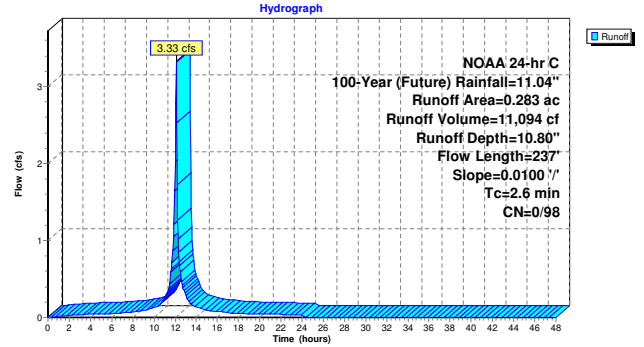

**Summary for Subcatchment 3S: P-1B Pervious**

Runoff = 15.77 cfs @ 12.21 hrs, Volume= 73,239 cf, Depth= 6.61"  
 Routed to Link 6L : POA #1

Runoff by SCS TR-20 method, UH=Delmarva, Split Pervious/Imperv., Time Span= 0.00-48.00 hrs, dt= 0.05 hrs  
 NOAA 24-hr C 100-Year (Future) Rainfall=11.04"

Area (ac)	CN	Description
1.849	61	>75% Grass cover, Good, HSG B
1.204	74	>75% Grass cover, Good, HSG C
3.053	66	Weighted Average
3.053	66	100.00% Pervious Area

Tc (min)	Length (feet)	Slope (ft/ft)	Velocity (ft/sec)	Capacity (cfs)	Description
8.9	100	0.0200	0.19		Sheet Flow, Grass: Short n= 0.150 P2= 3.88"
2.5	328	0.0180	2.16		Shallow Concentrated Flow, Unpaved Kv= 16.1 fps
11.4	428				Total

**Subcatchment 3S: P-1B Pervious**

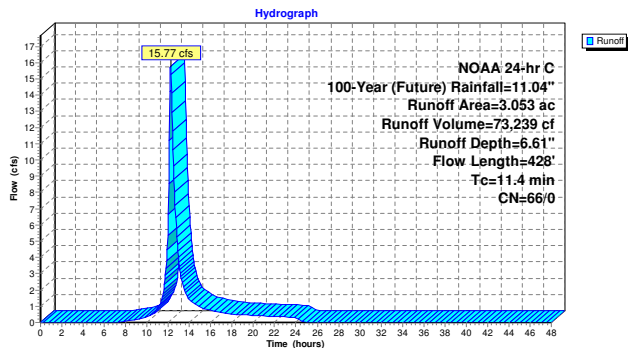

**Summary for Subcatchment 4S: P-2 Pervious**

Runoff = 2.04 cfs @ 12.10 hrs, Volume= 5,631 cf, Depth= 5.90"  
 Routed to Link 7L : POA #2

Runoff by SCS TR-20 method, UH=Delmarva, Split Pervious/Imperv., Time Span= 0.00-48.00 hrs, dt= 0.05 hrs  
 NOAA 24-hr C 100-Year (Future) Rainfall=11.04"

Area (ac)	CN	Description
0.263	61	>75% Grass cover, Good, HSG B
0.263	61	100.00% Pervious Area

Tc (min)	Length (feet)	Slope (ft/ft)	Velocity (ft/sec)	Capacity (cfs)	Description
2.5	43	0.0900	0.29		Sheet Flow, Grass: Short n= 0.150 P2= 3.88"

**Subcatchment 4S: P-2 Pervious**

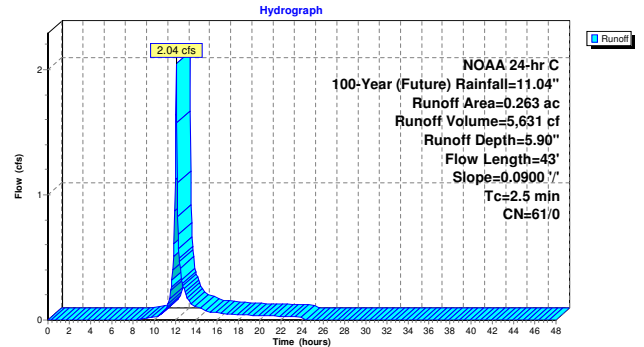

**Summary for Subcatchment 11S: P-1A Impervious**

Runoff = 4.40 cfs @ 12.13 hrs, Volume= 17,365 cf, Depth=10.80"  
 Routed to Pond 8P : StormTech

Runoff by SCS TR-20 method, UH=Delmarva, Split Pervious/Imperv., Time Span= 0.00-48.00 hrs, dt= 0.05 hrs  
 NOAA 24-hr C 100-Year (Future) Rainfall=11.04"

Area (ac)	CN	Description
0.443	98	
0.443	98	100.00% Impervious Area

Tc (min)	Length (feet)	Slope (ft/ft)	Velocity (ft/sec)	Capacity (cfs)	Description
5.0					Direct Entry, roof

**Subcatchment 11S: P-1A Impervious**

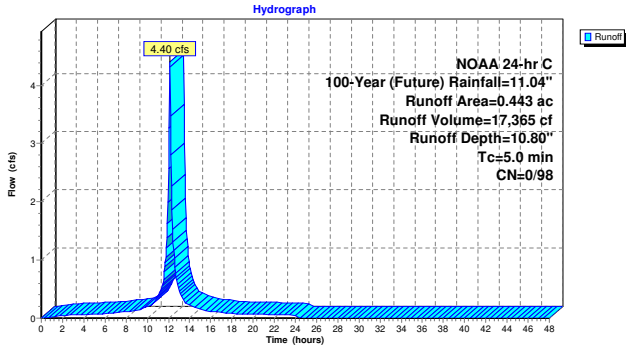

**Summary for Pond 8P: StormTech**

Inflow Area = 19,297 sf, 100.00% Impervious, Inflow Depth = 10.80" for 100-Year (Future) event  
 Inflow = 4.40 cfs @ 12.13 hrs, Volume= 17,365 cf  
 Outflow = 2.21 cfs @ 12.31 hrs, Volume= 16,395 cf, Atten= 50%, Lag= 10.8 min  
 Discarded = 0.06 cfs @ 12.31 hrs, Volume= 7,941 cf  
 Primary = 2.16 cfs @ 12.31 hrs, Volume= 8,453 cf  
 Routed to Link 6L : POA #1

Routing by Stor-Ind method, Time Span= 0.00-48.00 hrs, dt= 0.05 hrs  
 Peak Elev= 93.44' @ 12.31 hrs Surf.Area= 0.081 ac Storage= 0.172 af

Plug-Flow detention time= 437.0 min calculated for 16,395 cf (94% of inflow)  
 Center-of-Mass det. time= 403.3 min ( 1,143.5 - 740.2 )

Volume	Invert	Avail.Storage	Storage Description
#1A	90.00'	0.080 af	<b>39.50'W x 89.06'L x 3.75'H Field A</b> 0.303 af Overall - 0.102 af Embedded = 0.201 af x 40.0% Voids
#2A	90.75'	0.102 af	<b>ADS StormTech DC-780 +Cap</b> x 96 Inside #1 Effective Size= 45.4"W x 30.0"H => 6.49 sf x 7.12'L = 46.2 cf Overall Size= 51.0"W x 30.0"H x 7.56'L with 0.44' Overlap 96 Chambers in 8 Rows
		0.182 af	Total Available Storage

Storage Group A created with Chamber Wizard

Device	Routing	Invert	Outlet Devices
#1	Discarded	90.00'	<b>0.500 in/hr Exfiltration over Surface area</b> Conductivity to Groundwater Elevation = 81.00'
#2	Primary	92.15'	<b>6.0" W x 12.0" H Vert. Orifice1</b> C= 0.600 Limited to weir flow at low heads
#3	Primary	93.42'	<b>48.0" W x 4.0" H Vert. Orifice #2</b> C= 0.600 Limited to weir flow at low heads

Discarded OutFlow Max=0.06 cfs @ 12.31 hrs HW=93.44' (Free Discharge)  
 1-Exfiltration ( Controls 0.06 cfs)

Primary OutFlow Max=2.13 cfs @ 12.31 hrs HW=93.44' (Free Discharge)  
 2-Orifice1 (Orifice Controls 2.10 cfs @ 4.20 fps)  
 3-Orifice #2 (Orifice Controls 0.03 cfs @ 0.44 fps)

**Pond 8P: StormTech**

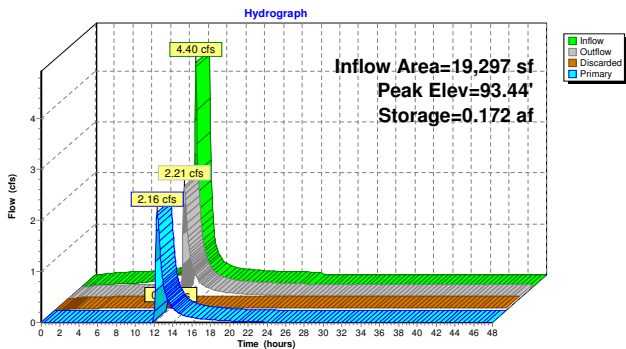

**Pond 8P: StormTech**

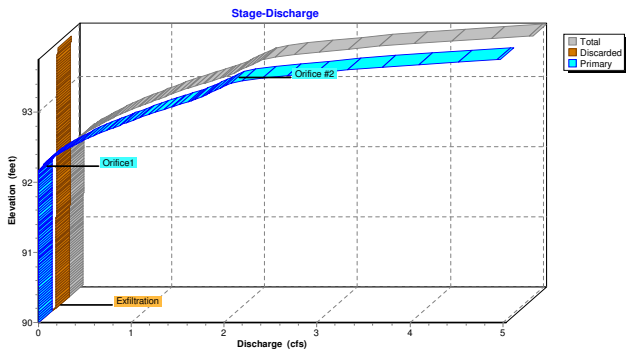

**Pond 8P: StormTech**

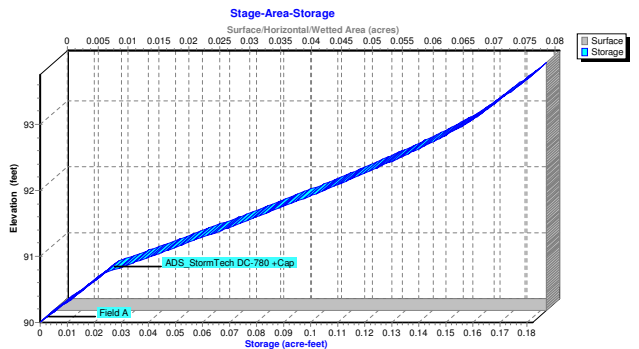

Summary for Link 6L: POA #1

Inflow Area = 373,222 sf, 64.37% Impervious, Inflow Depth = 9.02" for 100-Year (Future) event  
Inflow = 65.78 cfs @ 12.13 hrs, Volume= 280,513 cf  
Primary = 65.78 cfs @ 12.13 hrs, Volume= 280,513 cf, Atten= 0%, Lag= 0.0 min  
Routed to nonexistent node 10L

Primary outflow = Inflow, Time Span= 0.00-48.00 hrs, dt= 0.05 hrs

Link 6L: POA #1

Hydrograph

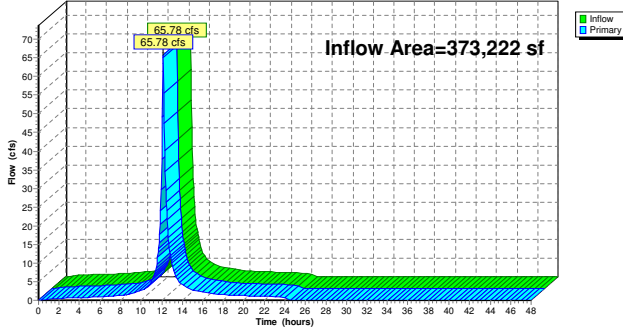

Summary for Link 7L: POA #2

Inflow Area = 23,784 sf, 51.83% Impervious, Inflow Depth = 8.44" for 100-Year (Future) event  
Inflow = 5.37 cfs @ 12.10 hrs, Volume= 16,724 cf  
Primary = 5.37 cfs @ 12.10 hrs, Volume= 16,724 cf, Atten= 0%, Lag= 0.0 min  
Routed to nonexistent node 10L

Primary outflow = Inflow, Time Span= 0.00-48.00 hrs, dt= 0.05 hrs

Link 7L: POA #2

Hydrograph

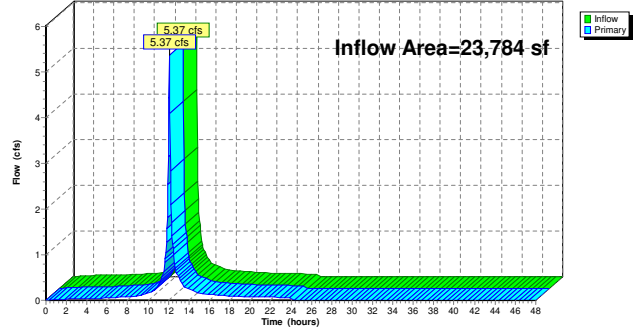

## **APPENDIX D: STORMWATER CONVEYANCE DESIGN**



## Storm Data Detailed Report: User Defined IDF Table - 1

### Element Details

ID	83	Notes
Label	User Defined IDF Table - 1	

Duration (min)	25 Year (in/h)
5.000	7.420
10.000	5.910
15.000	4.990
30.000	3.700
60.000	2.460

### Library Status Summary

Synchronization Details	
ID	83
Label	User Defined IDF Table - 1
Modified Date	6/24/2025 2:54:54 PM
Library Source	Orphan (local)
Library Modified Date	Orphan (local)
Synchronization Status	Orphan (local)
Engineering Reference Guid	Orphan (local)

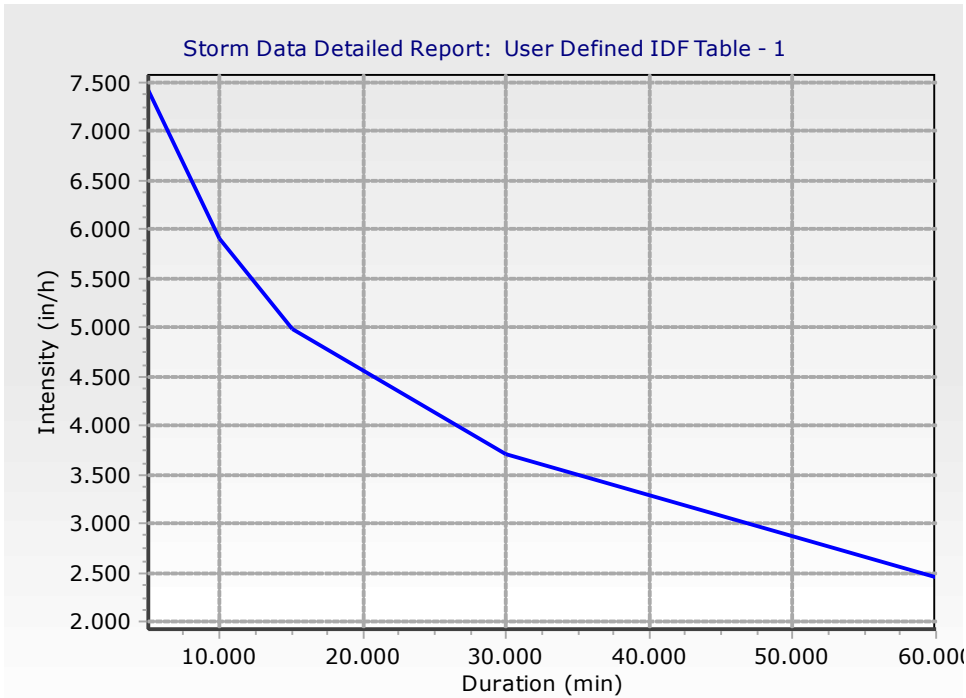



### Conduit FlexTable: Combined Pipe/Node Report

Label	Start Node	Stop Node	Length (Unified) (ft)	Diameter (in)	Manning's n	Slope (Calculated) (ft/ft)	Upstream Inlet Area (acres)	System CA (acres)	System Intensity (in/h)	Flow (cfs)	Capacity (Design) (cfs)	Velocity (ft/s)	Invert (Start) (ft)	Invert (Stop) (ft)	Elevation Ground (Start) (ft)	Elevation Ground (Stop) (ft)	Cover (Start) (ft)	Cover (Stop) (ft)	Hydraulic Grade Line (In) (ft)	Hydraulic Grade Line (Out) (ft)
1-100	YD-1	I-100	64.0	12.0	0.012	0.010	0.081	0.371	5.805	2.17	3.86	5.06	100.92	100.28	105.00	103.77	3.08	2.49	101.55	100.82
2-1	YD-2	YD-1	41.0	12.0	0.012	0.010	0.067	0.321	5.831	1.89	3.86	4.89	101.33	100.92	105.00	105.00	2.67	3.08	101.92	101.55
3-2	YD-3	YD-2	34.0	12.0	0.012	0.010	0.147	0.102	5.910	0.61	3.86	3.58	101.67	101.33	105.00	105.00	2.33	2.67	101.99	101.92
4-2	YD-4	YD-2	34.0	12.0	0.012	0.010	0.072	0.178	5.856	1.05	3.86	4.18	101.67	101.33	105.00	105.00	2.33	2.67	102.10	101.92
5-4	YD-5	YD-4	23.0	12.0	0.012	0.010	0.060	0.133	5.874	0.79	3.86	3.86	101.90	101.67	105.00	105.00	2.10	2.33	102.27	102.10
6-5	YD-6	YD-5	41.0	12.0	0.012	0.010	0.147	0.091	5.910	0.54	3.86	3.47	102.31	101.90	105.00	105.00	1.69	2.10	102.62	102.27
7-101	YD-7	I-101	10.0	12.0	0.012	0.006	0.021	0.427	5.766	2.48	2.99	4.25	98.39	98.33	102.40	101.60	3.01	2.27	99.09	99.03
8-7	YD-8	YD-7	56.0	12.0	0.012	0.006	0.041	0.187	5.815	1.10	3.01	3.53	98.73	98.39	102.00	102.40	2.27	3.01	99.17	99.09
9-8	YD-9	YD-8	48.0	12.0	0.012	0.006	0.069	0.152	5.859	0.90	3.00	3.34	99.02	98.73	102.00	102.00	1.98	2.27	99.42	99.17
10-9	YD-10	YD-9	48.0	12.0	0.012	0.006	0.112	0.095	5.910	0.56	2.95	2.89	99.30	99.02	102.00	102.00	1.70	1.98	99.61	99.42
11-7	YD-11	YD-7	17.0	12.0	0.012	0.006	0.032	0.221	5.820	1.30	2.96	3.65	98.49	98.39	102.00	102.00	2.51	3.01	99.09	99.09
12-11	YD-12	YD-11	47.0	12.0	0.012	0.006	0.093	0.189	5.861	1.12	2.98	3.52	98.77	98.49	102.00	102.00	2.23	2.51	99.22	99.09
13-12	YD-13	YD-12	49.0	12.0	0.012	0.006	0.132	0.111	5.910	0.66	3.02	3.08	99.07	98.77	102.00	102.00	1.93	2.23	99.41	99.22
14-305	YD-14	I-305	50.0	15.0	0.015	0.010	0.036	0.373	5.713	2.15	5.60	4.26	91.49	90.99	97.00	95.38	4.26	3.14	92.07	91.59
15-14	YD-15	YD-14	62.0	15.0	0.012	0.016	0.191	0.351	5.745	2.03	8.89	5.88	95.00	94.00	98.00	97.00	1.75	1.75	95.57	94.41
16-15	YD-16	YD-15	105.0	15.0	0.012	0.027	0.048	0.247	5.796	1.44	11.41	6.36	97.79	95.00	102.00	98.00	2.96	1.75	98.26	95.57
17-16	YD-17	YD-16	57.0	15.0	0.012	0.010	0.034	0.213	5.836	1.25	7.00	4.31	98.36	97.79	102.00	102.00	2.39	2.96	98.80	98.26
18-17	YD-18	YD-17	41.0	15.0	0.012	0.010	0.108	0.134	5.870	0.79	6.91	3.74	98.76	98.36	101.50	102.00	1.49	2.39	99.11	98.80
19-18	YD-19	YD-18	42.0	15.0	0.012	0.010	0.107	0.078	5.910	0.47	6.91	3.21	99.17	98.76	102.00	101.50	1.58	1.49	99.44	99.11
20-17	YD-20	YD-17	64.0	15.0	0.012	0.010	0.077	0.059	5.910	0.35	7.00	2.97	99.00	98.36	102.00	102.00	1.75	2.39	99.23	98.80
100-101	I-100	I-101	174.0	18.0	0.015	0.008	0.198	0.553	5.766	3.21	8.14	4.33	99.22	97.83	103.77	101.60	3.05	2.27	99.90	99.03
101-102	I-101	I-102	103.0	18.0	0.015	0.008	0.494	1.395	5.643	7.94	8.12	5.24	97.83	97.01	101.60	101.45	2.27	2.94	99.03	98.10
102-103	I-102	I-103	173.0	24.0	0.015	0.006	0.577	1.923	5.582	10.82	15.20	5.25	96.51	95.47	101.45	101.35	2.94	3.88	97.76	96.84
103-104	I-103	MH-104	68.0	24.0	0.015	0.006	0.367	2.245	5.482	12.41	15.22	5.40	95.47	95.06	101.35	101.35	3.88	4.34	96.84	96.42
104-105	MH-104	MH-105	106.0	24.0	0.015	0.006	(N/A)	2.245	5.443	12.32	15.23	5.40	95.06	94.42	101.40	103.55	4.34	7.13	96.42	95.68
200-Marlton Pike	I-200	Marlton Pike	105.0	15.0	0.015	0.016	0.630	0.449	5.910	2.67	7.10	5.38	93.00	91.31	97.65	94.03	3.40	1.47	93.66	91.84
300-301	I-300	I-301	95.0	18.0	0.015	0.010	0.474	0.399	5.910	2.38	9.10	4.33	95.67	94.72	100.00	98.59	2.83	2.37	96.25	95.67
301-304	I-301	I-304	107.0	18.0	0.015	0.010	0.807	1.019	5.843	6.00	9.10	5.50	94.72	93.65	98.59	98.71	2.37	3.56	95.67	94.83
304-305	I-304	I-305	194.0	18.0	0.015	0.015	0.772	1.600	5.783	9.33	11.15	7.06	93.65	90.74	98.71	95.38	3.56	3.14	94.83	91.79
305-Exist MH	I-305	EX-MH	103.0	21.0	0.015	0.021	0.388	2.228	5.677	12.75	20.11	8.85	90.26	88.05	95.38	96.36	3.37	6.56	91.59	89.06
306-Exist MH	I-306	EX-MH	132.0	24.0	0.015	0.001	0.933	0.749	5.910	4.72	6.61	2.29	86.42	86.27	93.36	96.36	4.94	8.09	87.68	87.54
400	I-400	Lippincott Dr	82.0	15.0	0.015	0.019	0.491	0.402	5.910	2.40	7.80	5.59	99.47	97.88	102.67	103.38	1.95	4.25	100.09	98.36
CO-8	EX-MH	O-3	329.0	42.0	0.015	0.006	(N/A)	2.977	5.641	17.19	67.98	5.89	86.27	84.27	96.36	92.21	6.59	4.44	87.54	85.47
OCS1-306	OCS-1	I-306	41.0	18.0	0.015	0.020	(N/A)	0.000	7.420	0.26	12.87	2.89	87.74	86.92	94.55	93.36	5.31	4.94	87.93	87.68



**APPENDIX E: ADS STORMTECH**



**Proposed Conditions-Current\_Rev1**

Prepared by Taylor, Wiseman, Taylor

HydroCAD® 10.20-2h s/n 04583 © 2024 HydroCAD Software Solutions LLC

NJ DEP 2-hr WQ Rainfall=1.25"

Printed 8/27/2025

**Pond 8P: StormTech - Chamber Wizard Field A**

**Chamber Model = ADS\_StormTech DC-780 +Cap (ADS StormTech® DC-780 with cap length)**

Effective Size= 45.4"W x 30.0"H => 6.49 sf x 7.12'L = 46.2 cf

Overall Size= 51.0"W x 30.0"H x 7.56'L with 0.44' Overlap

51.0" Wide + 6.0" Spacing = 57.0" C-C Row Spacing

12 Chambers/Row x 7.12' Long +0.81' Cap Length x 2 = 87.06' Row Length +12.0" End Stone x 2 = 89.06' Base Length

8 Rows x 51.0" Wide + 6.0" Spacing x 7 + 12.0" Side Stone x 2 = 39.50' Base Width

9.0" Stone Base + 30.0" Chamber Height + 6.0" Stone Cover = 3.75' Field Height

96 Chambers x 46.2 cf = 4,438.9 cf Chamber Storage

13,191.5 cf Field - 4,438.9 cf Chambers = 8,752.6 cf Stone x 40.0% Voids = 3,501.0 cf Stone Storage

Chamber Storage + Stone Storage = 7,940.0 cf = 0.182 af

Overall Storage Efficiency = 60.2%

Overall System Size = 89.06' x 39.50' x 3.75'

96 Chambers

488.6 cy Field

324.2 cy Stone

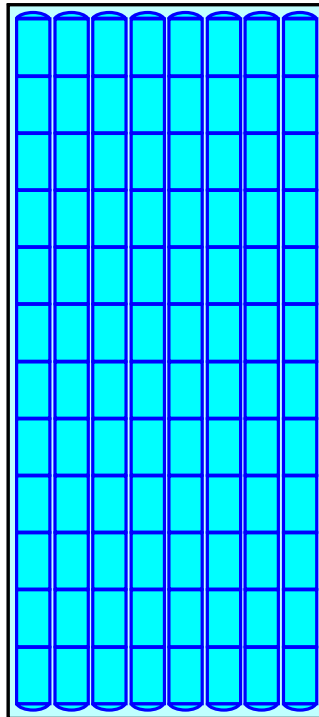



# StormTech® DC-780 Chamber

Designed to meet the most stringent industry performance standards for superior structural integrity while providing designers with a cost-effective method to save valuable land and protect water resources. The StormTech system is designed primarily to be used under parking lots, thus maximizing land usage for private (commercial) and public applications. StormTech chambers can also be used in conjunction with Green Infrastructure, thus enhancing the performance and extending the service life of these practices.

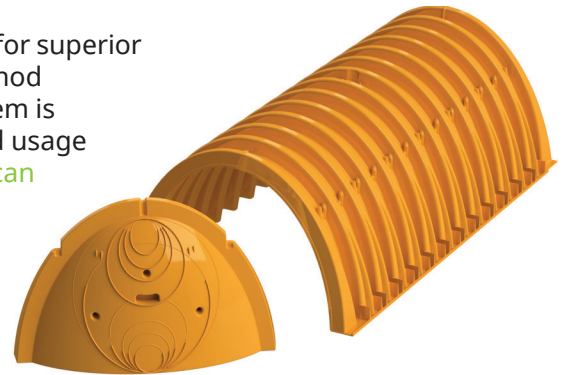

- 12' (3.6 m) Deep Cover Applications
- Designed in accordance with ASTM F2787 and produced to meet the ASTM F2418 product standard.
- AASHTO safety factors provided for AASHTO Design Truck (H2O and deep cover conditions.)

## Nominal Chamber Specifications

(not to scale)

### Size (L x W x H)

85.4" x 51" x 30"  
2169 mm x 1,295 mm x 762 mm

### Chamber Storage

46.2 ft<sup>3</sup> (1.30 m<sup>3</sup>)

### Min. Installed Storage\*

78.4 ft<sup>3</sup> (2.20 m<sup>3</sup>)

### Weight

80.0 lbs (36.3 kg)

### Shipping

25 chambers/pallet  
60 end caps/pallet  
12 pallets/truck

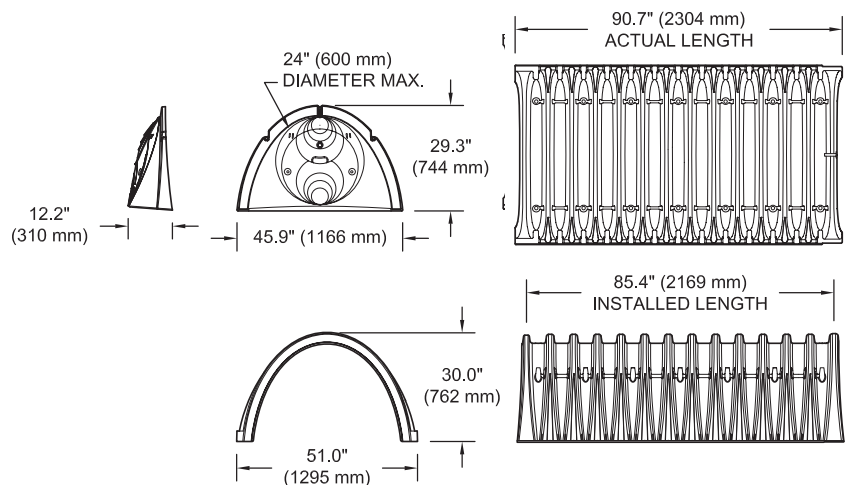

\*Assumes 9" (230 mm) stone below, 6" (150 mm) row spacing and 40% stone porosity.

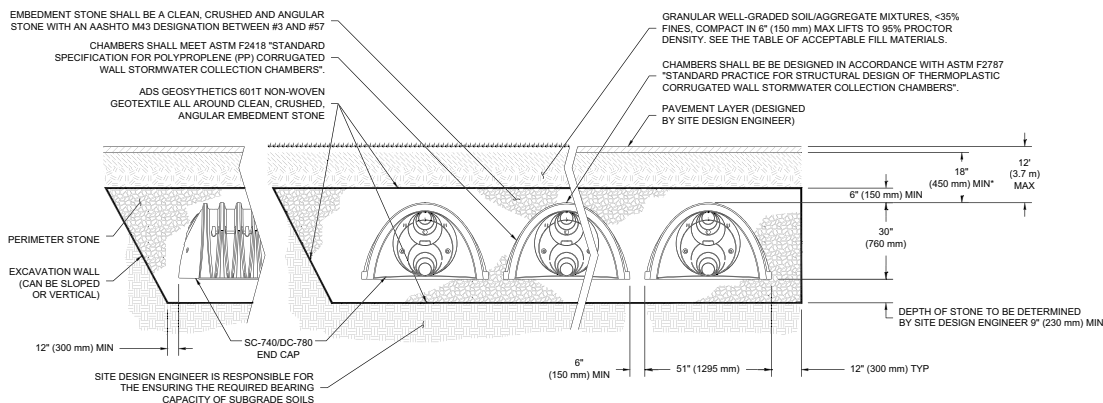

\*MINIMUM COVER TO BOTTOM OF FLEXIBLE PAVEMENT. FOR UNPAVED INSTALLATIONS WHERE RUTTING FROM VEHICLES MAY OCCUR, INCREASE COVER TO 24" (600 mm).

# StormTech DC-780 Specifications

## Cumulative Storage Volumes Per Chamber

Assumes 40% Stone Porosity. Calculations are Based Upon a 9" (230 mm) Stone Base Under Chambers.

Depth of Water in System Inches (mm)	Cumulative Chamber Storage ft <sup>3</sup> (m <sup>3</sup> )	Total System Cumulative Storage ft <sup>3</sup> (m <sup>3</sup> )
45 (1,143)	46.27 (1.310)	78.47 (2.222)
44 (1,118)	46.27 (1.310)	77.34 (2.190)
43 (1,092)	46.27 (1.310)	76.21 (2.158)
42 (1,067)	46.27 (1.310)	75.09 (2.126)
41 (1,041)	46.27 (1.310)	73.96 (2.094)
40 (1,016)	46.27 (1.310)	72.83 (2.062)
39 (991)	46.27 (1.310)	71.71 (2.030)
38 (965)	46.21 (1.309)	70.54 (1.998)
37 (940)	46.04 (1.304)	69.32 (1.963)
36 (914)	45.76 (1.296)	68.02 (1.926)
35 (889)	45.15 (1.278)	66.53 (1.884)
34 (864)	44.34 (1.255)	64.91 (1.838)
33 (838)	43.38 (1.228)	63.21 (1.790)
32 (813)	42.29 (1.198)	61.43 (1.740)
31 (787)	41.11 (1.164)	59.59 (1.688)
30 (762)	39.83 (1.128)	57.70 (1.634)
29 (737)	38.47 (1.089)	55.76 (1.579)
28 (711)	37.01 (1.048)	53.76 (1.522)
27 (686)	35.49 (1.005)	51.72 (1.464)
26 (660)	33.90 (0.960)	49.63 (1.405)
25 (635)	32.24 (0.913)	47.52 (1.346)
24 (610)	30.54 (0.865)	45.36 (1.285)
23 (584)	28.77 (0.815)	43.18 (1.223)
22 (559)	26.96 (0.763)	40.97 (1.160)
21 (533)	25.10 (0.711)	38.72 (1.096)
20 (508)	23.19 (0.657)	36.45 (1.032)
19 (483)	21.25 (0.602)	34.16 (0.967)
18 (457)	19.26 (0.545)	31.84 (0.902)
17 (432)	17.24 (0.488)	29.50 (0.835)
16 (406)	15.19 (0.430)	27.14 (0.769)
15 (381)	13.10 (0.371)	24.76 (0.701)
14 (356)	10.98 (0.311)	22.36 (0.633)
13 (330)	8.83 (0.250)	19.95 (0.565)
12 (305)	6.66 (0.189)	17.52 (0.496)
11 (279)	4.46 (0.126)	15.07 (0.427)
10 (254)	2.24 (0.064)	12.61 (0.357)
9 (229)	0 (0)	10.14 (0.287)
8 (203)	0 (0)	9.01 (0.255)
7 (178)	0 (0)	7.89 (0.223)
6 (152)	0 (0)	6.76 (0.191)
5 (127)	0 (0)	5.63 (0.160)
4 (102)	0 (0)	4.51 (0.128)
3 (76)	0 (0)	3.38 (0.096)
2 (51)	0 (0)	2.25 (0.064)
1 (25)	0 (0)	1.13 (0.032)

Note: Add 1.13 ft<sup>3</sup> (0.032 m<sup>3</sup>) of Storage for Each Additional Inch (25 mm) of Stone Foundation.

## Storage Volume Per Chamber ft<sup>3</sup> (m<sup>3</sup>)

	Bare Chamber Storage ft <sup>3</sup> (m <sup>3</sup> )	Chamber and Stone Foundation Depth in. (mm)		
		6 (150)	12 (300)	18 (450)
DC-780 Chamber	78.4 (2.2)	78.4 (2.2)	81.8 (2.3)	88.6 (2.5)

Note: Assumes 40% porosity for the stone, the bare chamber volume, 6" (150 mm) of stone above, and 6" (150 mm) row spacing.

## Amount of Stone Per Chamber

English Tons (yds <sup>3</sup> )	Stone Foundation Depth		
	6"	12"	18"
DC-780	4.2 (3.0)	4.7 (3.3)	5.6 (3.9)
Metric Kilograms (m <sup>3</sup> )	150 mm	300 mm	450 mm
DC-780	3,810 (2.3)	4,264 (2.5)	5,080 (3.0)

Note: Assumes 6" (150 mm) of stone above, and between chambers.

## Volume Excavation Per Chamber yd<sup>3</sup> (m<sup>3</sup>)

	Stone Foundation Depth		
	6 (150)	12 (300)	18 (450)
DC-780	5.9 (4.5)	6.3 (4.8)	6.9 (5.3)

Note: Assumes 6" (150 mm) separation between chamber rows and 18" (450 mm) of cover. The volume of excavation will vary as depth of cover increases.

ADS StormTech products, manufactured in accordance with ASTM F2418 or ASTM F2922, comply with all requirements in the Build America, Buy America (BABA) Act.

## Working on a project?

Visit us at [adspipe.com/stormtech](https://adspipe.com/stormtech) and utilize the Design Tool



adspipe.com

800-821-6710

## **APPENDIX F: GROUNDWATER RECHARGE**





Project Name		Description		Analysis Date		BMP or LID Type									
Marlton Crossing		0		08/27/25		ADS STORMTECH DC780									
Recharge BMP Input Parameters				Root Zone Water Capacity Calculated Parameters				Recharge Design Parameters							
Parameter	Symbol	Value	Unit	Parameter	Symbol	Value	Unit	Parameter	Symbol	Value	Unit				
BMP Area	ABMP	3517.0	sq.ft	Empty Portion of RWC under Post-D Natural Recharge	ERWC	0.89	in	Inches of Runoff to capture	Odesign	2.78	in				
BMP Effective Depth, this is the design variable Upper level of the BMP surface (negative if above ground)	dBMP	19.8	in	ERWC Modified to consider dEXC	EDRWC	0.00	in	Inches of Rainfall to capture	Pdesign	3.01	in				
Depth of lower surface of BMP, must be >= dBMPu	dBMPu	15.0	in	Empty Portion of RWC under Infiltr. BMP	RERWC	0.00	in	Recharge Provided Avg. over imp. Area		35.0	in				
	dEXC	60.0	in					Runoff Captured Avg. over imp. Area		35.0	in				
Post-development Land Segment Location of BMP, Input Zero if Location is distributed or undetermined	SegBMP	1	unitless												
CALCULATION CHECK MESSAGES															
Volume Balance -> <b>Solve Problem to satisfy Annual Recharge</b>															
dBMP Check -> <b>OK</b>															
dEXC Check -> <b>OK</b>															
BMP Location -> <b>OK</b>															
OTHER NOTES															
Pdesign is accurate only after BMP dimensions are updated to make rech volume= deficit volume. The portion of BMP infiltration prior to filling and the area occupied by BMP are ignored in these calculations. Results are sensitive to dBMP, make sure dBMP selected is small enough for BMP to empty in less than 3 days. For land Segment Location of BMP if you select "impervious areas" RWC will be minimal but not zero as determined by the soil type and a shallow root zone for this Land Cover allowing consideration of lateral flow and other losses															
BMP Calculated Size Parameters															
ABMP/Aimp				Aratio				0.18				unitless			
BMP Volume				VBMP				5,803				cu.ft			
System Performance Calculated Parameters															
Annual BMP Recharge Volume				56,216				cu.ft							
Avg BMP Recharge Efficiency				100.0%				Represents % Infiltration Recharged							
%Rainfall became Runoff				77.8%				%							
%Runoff Infiltrated				100.0%				%							
%Runoff Recharged				7.9%				%							
%Rainfall Recharged				6.1%				%							
Parameters from Annual Recharge Worksheet															
Post-D Deficit Recharge (or desired recharge volume)				Vdef				4,556				cu.ft			
Post-D Impervious Area (or target Impervious Area)				Aimp				19,279				sq.ft			
Root Zone Water Capacity				RWC				3.09				in			
RWC Modified to consider dEXC				DRWC				0.00				in			
Climatic Factor				C-factor				1.42				no units			
Average Annual P				Pavg				45.0				in			
Recharge Requirement over Imp. Area				dr				0.2				in			
<b>How to solve for different recharge volumes:</b> By default the spreadsheet assigns the values of total deficit recharge volume "Vdef" and total proposed impervious area "Aimp" from the "Annual Recharge" sheet to "Vdef" and "Aimp" on this page. This allows solution for a single BMP to handle the entire recharge requirement assuming the runoff from entire impervious area is available to the BMP. To solve for a smaller BMP or a LID-IMP to recharge only part of the recharge requirement, set Vdef to your target value and Aimp to impervious area directly connected to your infiltration facility and then solve for ABMP or dBMP. To go back to the default configuration click the "Default Vdef & Aimp" button.															

**APPENDIX G: GROUNDWATER MOUNDING ANALYSIS**



Taylor Wiseman & Taylor  
804 East Gate Drive, Suite 100  
Mount Laurel, New Jersey 08054  
Phone: 856-235-7200  
Fax: 856-722-9250

Proj No.: 07380.1000.01  
Evesham Township, Burlington County, NJ  
Drain Time - Small-Scale Basin #1

Revised:  
Date: 8/27/2025  
By: VAK

Use: **0.5** in/hr  
with a factor of safety of 2  
Minimum Design Permeability Rate = 0.50 in/hr  
Maximum Design Permeability Rate = 10 in/hr

Basin bottom Area = 3,518 s.f.  
Rate = 0.5 in/hr \* 1ft/12in \* 3,518 s.f. = 147 cuft/hr

Storage Volume = 4,965 cuft

$\frac{4,965 \text{ cuft}}{147 \text{ cuft/hr}} = 33.87 \text{ hrs} < 72 \text{ hours OKAY}$



Input Values

0.50
0.150
2.50
44.530
19.750
33.87
10.00

**R** Recharge rate (permeability rate) (in/hr)  
**Specific yield, Sy (dimensionless)**  
 default value is 0.15; max value is 0.2 provided that a lab test data is submitted  
**Horizontal hydraulic conductivity (in/hr)**  
 Kh = 5xRecharge Rate (R) in the costal plan; Kh=R outside the coastal plan  
**x** 1/2 length of basin (x direction, in feet)  
**y** 1/2 width of basin (y direction, in feet)  
**t** Duration of infiltration period (hours)  
**hi(0)** Initial thickness of saturated zone (feet)

15.583
5.583

**h(max)** Maximum thickness of saturated zone (beneath center of basin at end of infiltration period)  
**Δh(max)** Maximum groundwater mounding (beneath center of basin at end of infiltration period)

Distance from  
 Ground-water center of basin in x  
 Mounding, in feet direction, in feet

5.583	0
5.501	10
5.234	20
4.701	30
3.735	40
2.258	50
0.609	70
0.287	80
0.127	90
0.054	100



**Re-Calculate Now**

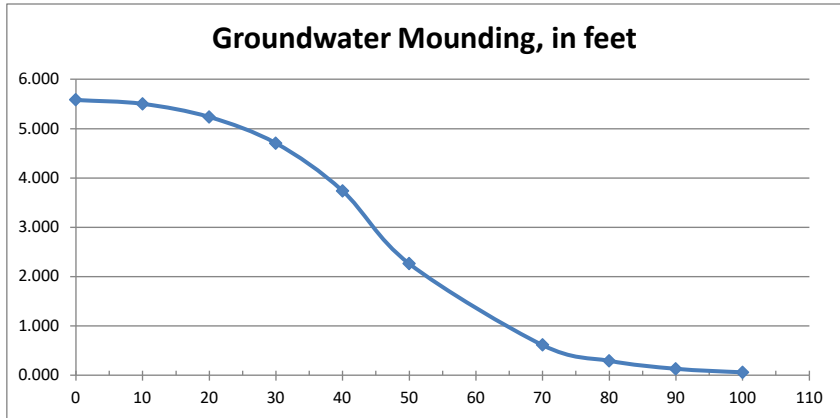

**Disclaimer**

This spreadsheet solving the Hantush (1967) equation for ground-water mounding beneath an infiltration basin is made available to the general public as a convenience for those wishing to replicate values documented in the USGS Scientific Investigations Report 2010-5102 "Groundwater mounding beneath hypothetical stormwater infiltration basins" or to calculate values based on user-specified site conditions. Any changes made to the spreadsheet (other than values identified as user-specified) after transmission from the USGS could have unintended, undesirable consequences. These consequences could include, but may not be limited to: erroneous output, numerical instabilities, and violations of underlying assumptions that are inherent in results presented in the accompanying USGS published report. The USGS assumes no responsibility for the consequences of any changes made to the spreadsheet. If changes are made to the spreadsheet, the user is responsible for documenting the changes and justifying the results and conclusions.



**APPENDIX H: EXISTING AND PROPOSED DRAINAGE PLANS**



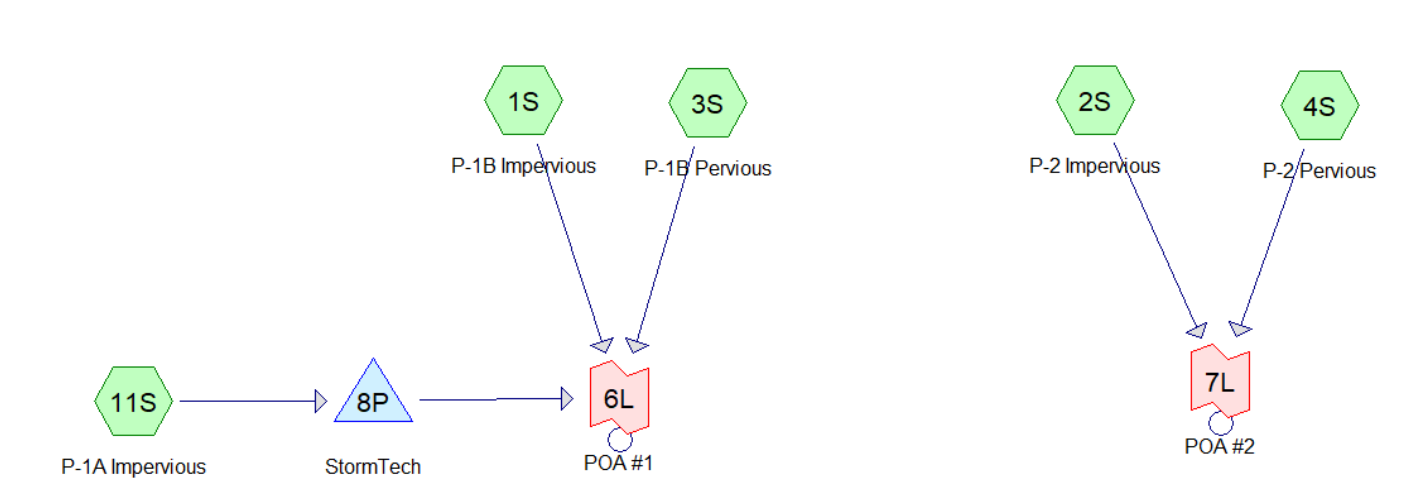
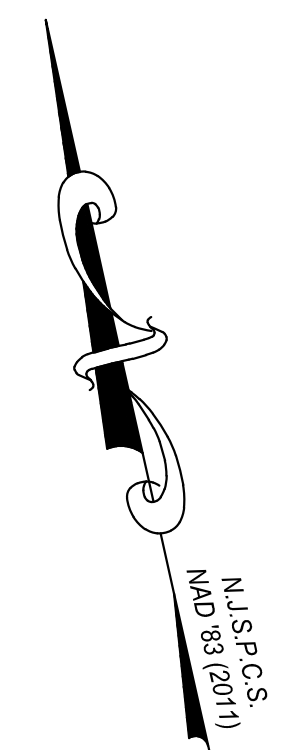
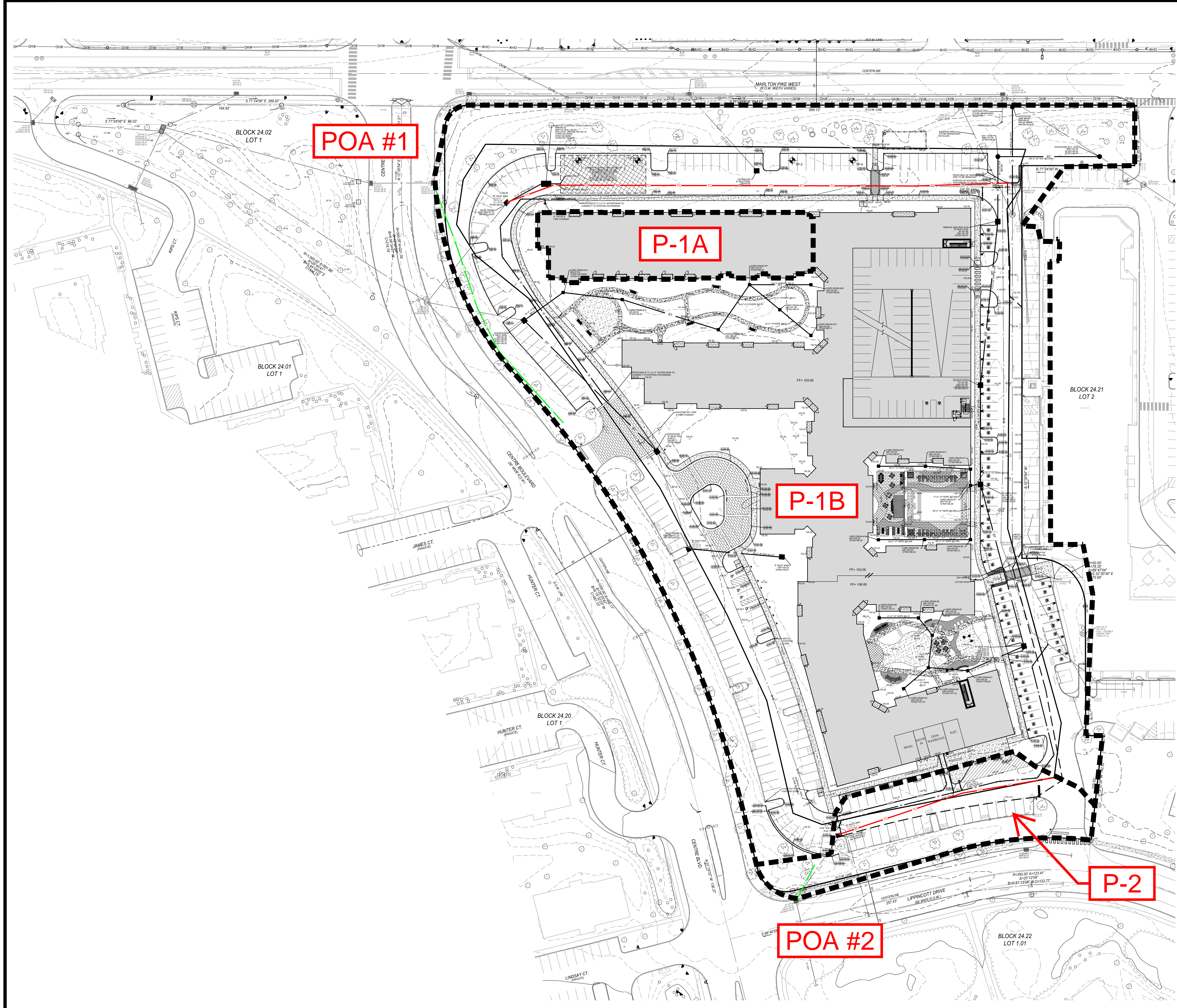

Drainage Area	Location	Area (Ac)	Cover Condition	Soil Group	Runoff Coeff.	Time of Concentration (min)	
						Current	Future
P-1A	POA #1	0.44	Impervious	-	98	5	5
		5.07	Impervious	-	98	4.4	4.3
P-1B	POA #1	1.85	Open Space	B	61	12.2	11.4
		1.2	Open Space	C	74		
P-2	POA #2	0.28	Impervious	-	98	2.7	2.6
		0.26	Open Space	B	61	2.7	2.5

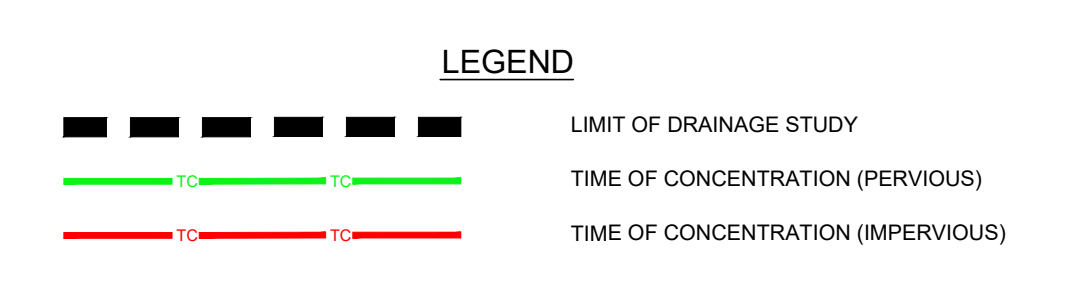

THIS PLAN IS FOR DRAINAGE AREA PURPOSES ONLY

**PROPOSED DRAINAGE AREA PLAN**

MARLTON CROSSING  
BLOCK 24.21, LOT 3, TAX MAP SHEET 4  
100 CENTRE BOULEVARD  
EVESHAM TOWNSHIP  
BURLINGTON COUNTY, NEW JERSEY

**Taylor Wiseman & Taylor**  
ENGINEERS / SURVEYORS / SCIENTISTS  
SUBSURFACE UTILITY ENGINEERING  
804 EAST GATE DRIVE, SUITE 100, MOUNT LAUREL, NJ 08054  
TELEPHONE: (856) 235-7200 FAX: (856) 722-9250 www.taylorwiseman.com  
NJ CERTIFICATE OF AUTHORIZATION NO. 24620002900

REVISIONS  
NO. DATE  
1 8/20/25

DATE: 8/24/2025 DRAWING NO.: 025-07380-PRDA SHEET: 1 OF 1

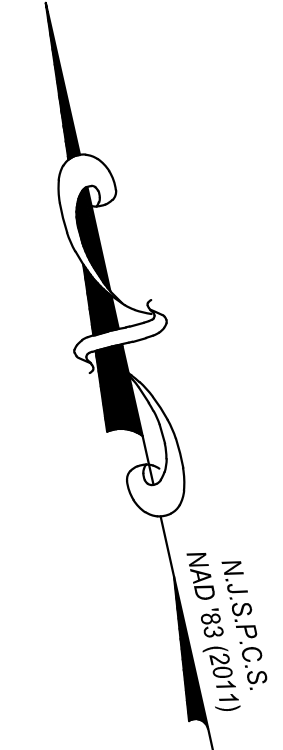
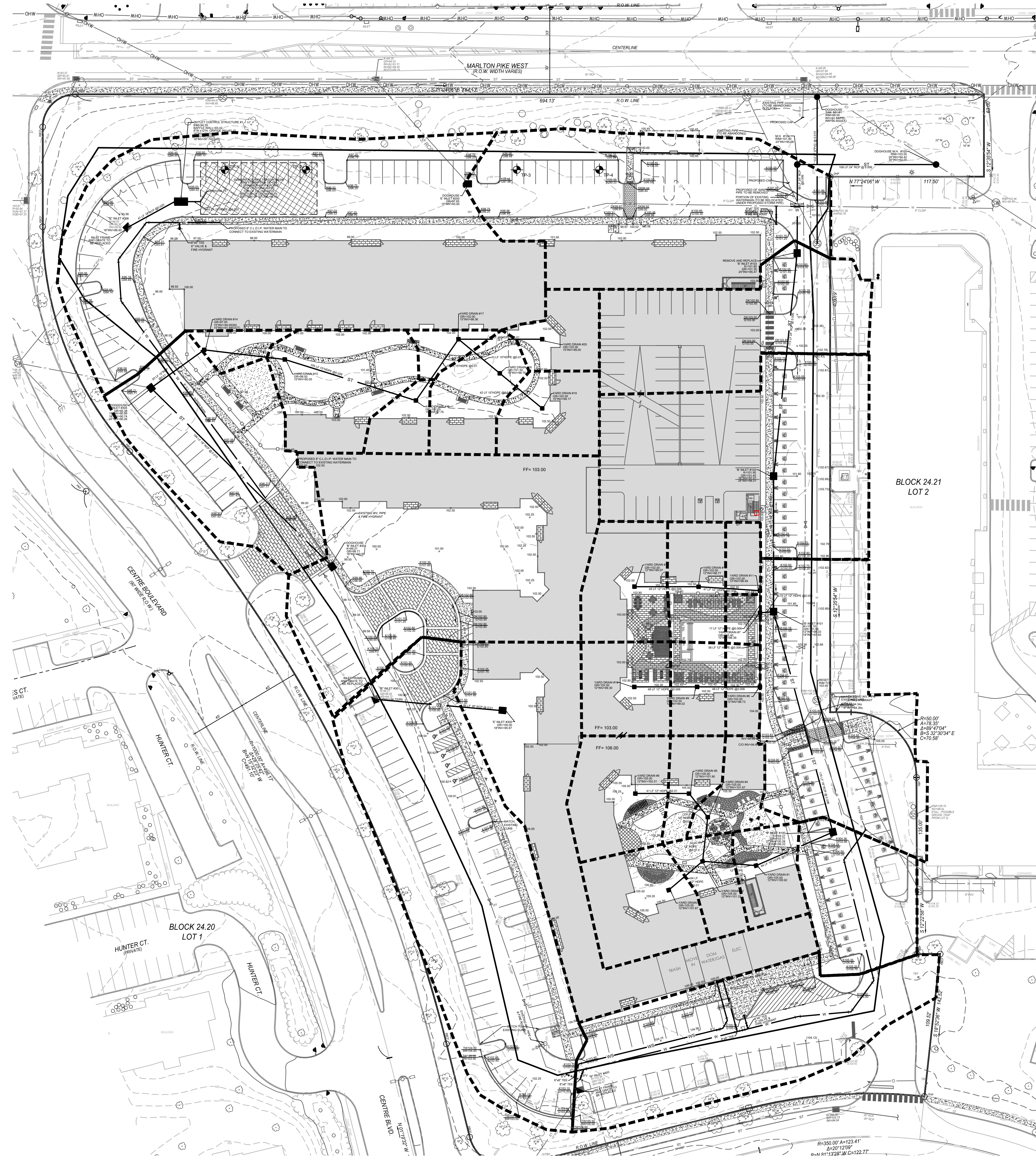

**LEGEND**  
 ■■■■■ INLET DRAINAGE AREA



THIS PLAN IS FOR DRAINAGE AREA PURPOSES ONLY

REVISIONS	NO.	DATE
	1	8/28/25

**INLET DRAINAGE AREA PLAN**  
 MARLTON CROSSING  
 BLOCK 24.21, LOT 3, TAX MAP SHEET 4  
 100 CENTRE BOULEVARD  
 EVESHAM TOWNSHIP  
 BURLINGTON COUNTY, NEW JERSEY

**Taylor Wiseman & Taylor**  
 ENGINEERS / SURVEYORS / SCIENTISTS  
 SUBSURFACE UTILITY ENGINEERING  
 804 EAST GATE DRIVE, SUITE 100, MOUNT LAUREL, NJ 08054  
 TELEPHONE: (856) 235-7200 FAX: (856) 722-9250 www.taylorwiseman.com  
 NJ CERTIFICATE OF AUTHORIZATION NO. 246200029000

SCALE	DATE	DRAWING NO.	SHEET
1"=40'	8/24/2025	025-07380-INDA	1 OF 1